



CITY *of* PERTH

MINUTES

PLANNING COMMITTEE

27 JANUARY 2016

**THESE MINUTES ARE HEREBY CERTIFIED AS
CONFIRMED**

**PRESIDING MEMBER'S
SIGNATURE**

DATE: 8/3/16

PLANNING COMMITTEE

INDEX

Item	Description	Page
PL1/16	DECLARATION OF OPENING	1
PL2/16	APOLOGIES AND MEMBERS ON LEAVE OF ABSENCE	1
PL3/16	QUESTION TIME FOR THE PUBLIC	1
PL4/16	CONFIRMATION OF MINUTES	2
PL5/16	CORRESPONDENCE	2
PL6/16	DISCLOSURE OF MEMBERS' INTERESTS	2
PL7/16	MATTERS FOR WHICH THE MEETING MAY BE CLOSED	2
PL8/16	251-253 (LOTS 10, 11 AND 412) ST GEORGES TERRACE, PERTH – INSTALLATION OF TWO “NEW TECHNOLOGY” SIGNS INCLUDING A LARGE DIGITAL SCREEN TO DISPLAY CHANNEL NINE NETWORK PROGRAMS AND ASSOCIATED ADVERTISING	3
PL9/16	FINAL ADOPTION OF AMENDMENT NO. 33 TO CITY PLANNING SCHEME NO. 2 – SPECIAL CONTROL AREA – 942 AND 950 HAY STREET AND 33 MILLIGAN STREET, PERTH	11
PL10/16	HERITAGE RATE CONCESSION APPLICATION FOR PROPERTY AT 45 WELLINGTON STREET, EAST PERTH	13
PL11/16	WATERBANK INFRASTRUCTURE AND PUBLIC DOMAIN WORKS – 3 (LOT 502) TRINITY AVENUE, EAST PERTH	16
PL12/16	BARRACK STREET – INTEGRATING PRIVATE REALM INVESTMENT WITH STREETScape WORKS – ANNUAL UPDATE	40
PL13/16	MOTIONS OF WHICH PREVIOUS NOTICE HAS BEEN GIVEN	47
PL14/16	GENERAL BUSINESS	47
PL15/16	ITEMS FOR CONSIDERATION AT A FUTURE MEETING	48
PL16/16	CLOSE OF MEETING	48

Minutes of the meeting of the City of Perth **Planning Committee** held in Committee Room 1, Ninth Floor, Council House, 27 St Georges Terrace, Perth on **Wednesday, 27 January 2016**.

MEMBERS IN ATTENDANCE

Cr McEvoy – Presiding Member
Cr Adamos
Cr Yong

OFFICERS

Mr Mileham – Acting Chief Executive Officer
Ms Moore – Director Community and Commercial Services
Mr Crosetta – Director Construction and Maintenance
Mr Carter – Director Economic Development and Activation
Ms Smith – Manager Development Approvals
Mr Ridgwell – Manager Governance
Mr McDougall – Interim Manager Economic Development
Mr Kay – Manager Activity Approvals (departed at 5.45pm)
Ms Handley – Acting Head, Project Management Office
Ms Denton – Governance Coordinator
Ms Ferguson – Principal Strategic Town Planner
Ms Emmons – Governance Officer

GUESTS AND DEPUTATIONS

Nil

PL1/16 DECLARATION OF OPENING

5.30pm The Presiding Member declared the meeting open.

PL2/16 APOLOGIES AND MEMBERS ON LEAVE OF ABSENCE

Nil

PL3/16 QUESTION TIME FOR THE PUBLIC

Nil

PL4/16 CONFIRMATION OF MINUTES

Moved by Cr Adamos, seconded by Cr Yong

That the minutes of the meeting of the Planning Committee held on 8 December 2015 be confirmed as a true and correct record.

The motion was put and carried

The votes were recorded as follows:

For: Crs McEvoy, Adamos and Yong

Against: Nil

PL5/16 CORRESPONDENCE

Nil

PL6/16 DISCLOSURE OF MEMBERS' INTERESTS

The following Members disclosed an interest:

Member / Officer	Minute No.	Item Title.	Nature / Extent of Interest
Cr Adamos	PL11/16	Waterbank Infrastructure and Public Domain Works – 3 (Lot 502) Trinity Avenue, East Perth	Impartiality Interest – Cr Adamos' children are students at Trinity College

PL7/16 MATTERS FOR WHICH THE MEETING MAY BE CLOSED

The Presiding Member advised that in accordance with Section 5.23(2) of the Local Government Act 1995, the meeting will be required to be closed to the public prior to discussion of the following:

Confidential Item No. and Schedule No.	Item No. and Title	Reason
Confidential Schedule No. 5	Minute Item No. PL10/16 – Heritage Rate Concession Application for Property at 45 Wellington Street, East Perth	Section 5.23(2)(e)(iii)

Confidential Item No. and Schedule No.	Item No. and Title	Reason
Confidential Schedules No. 8 and 9	Minute Item No. PL12/16 – Barrack Street – Integrating Private Realm Investment With Streetscape Works – Annual Update	Section 5.23(2)(e)(iii)

PL8/16 251-253 (LOTS 10, 11 AND 412) ST GEORGES TERRACE, PERTH – INSTALLATION OF TWO “NEW TECHNOLOGY” SIGNS INCLUDING A LARGE DIGITAL SCREEN TO DISPLAY CHANNEL NINE NETWORK PROGRAMS AND ASSOCIATED ADVERTISING

BACKGROUND:

SUBURB/LOCATION: 251-253 St Georges Terrace, Perth
 FILE REFERENCE: 2015/5504
 REPORTING UNIT: Development Approvals
 RESPONSIBLE DIRECTORATE: Planning and Development
 DATE: 6 January 2016
 MAP / SCHEDULE: Schedule 1 – Map, coloured perspectives, photos of 251-253 St Georges Terrace, Perth and line of sight plan
 Schedule 2 – Additional plans
 3D MODEL PRESENTATION: N/A

LANDOWNER: Primewest Funds Ltd
 APPLICANT: Cardno (WA) Pty Ltd
 ZONING: (MRS Zone) Central City Area Zone
 City Centre Use Area, St Georges Precinct (P6)
 (City Planning Scheme Use Area) City Centre

APPROXIMATE COST: \$650,000

SITE HISTORY:

The subject site is the eastern most lot of the three lots comprising the proposed Channel Nine studio area which is currently occupied by a seven storey office building and two levels of basement car parking accommodating 115 tenant car parking bays. The lot currently accommodates a landscaped forecourt known as ‘Eric Silberts Gardens’. This forecourt was granted planning approval by Council at its meeting held **17 March 1986**. The approval was conditional to a lease agreement being made with the City of Perth (the City) for a 25 year period that ensured the landscaped area was free for the public to use. This agreement was negotiated with the City on a pepper corn lease which expired 2 November 2011. Ground and first level alterations to the seven storey office building on the lot were approved by Council at its meeting held on **19 February 2013** and have been undertaken.

At its meeting held on 18 September 2015, the City of Perth Local Development Assessment Panel approved the construction of new single storey television studio, refurbishments to two existing office buildings, an enclosed pedestrian walkway connecting the two buildings, landscaping to the remaining forecourt, modifications to existing car parking and end of trip facilities at 251, 255 & 267 (Lots 10, 11 and 412) St Georges Terrace, Perth. The approved development is designated to be the new Channel Nine studios in Perth and its associated offices and facilities. The forecourt is intended to form an 'urban park' for day to day use by the public as well as potentially provide a small amphitheatre for events and gatherings. This development application indicated the intent to erect a large digital screen to assist in the activation of the forecourt that would display Channel Nine programs and events, but it did not form part of the original application.

DETAILS:

The applicant seeks development approval to install two 'new technology' signs at the subject site.

A 7 metre wide and 3.5 metre high full colour LED digital screen is proposed to be located on the western façade of the existing office tower on the site, facing east onto the public plaza as approved in 2015. The screen will mainly display the live screening of the Channel Nine Network free to air channels (Nine, Nine Go, Nine GEM, Nine Life, extra). A live stream is defined as a program being simulcast to the video screen at the same time as its available to Nine viewers in their home. This live stream will also include commercials breaks where third party advertising will be shown. On occasion the screen may be used for airing other program material which may be available to Channel Nine viewers in other areas, but not necessarily to viewers in Perth Metropolitan area. An example of this is cricket being played locally in Perth, which is not being broadcast in Perth, but is being broadcast in other states.

The applicant is also proposing to extend its relationship with its clients by offering additional commercial slots to existing clients exclusively on the plaza video screen. The screen is also proposed to be used for station promotion material either moving or still frame which may also include video support of a Channel Nine marketing and promotional exercise to be hosted in the Channel Nine Plaza.

The second sign will be a digital 'ticker' sign incorporated into the design of the new single storey studio building, which is proposed to run below a perforated folded anodised screen to the outside of the building along the eastern façade and wrap around to the northern façade of the building. The sign will measure 0.3 metres in height, 24 metres in length and 0.2 metres in depth. The content to be displayed on the digital 'ticker' sign will be confined to a single line of text which will scroll across the façade of the studio and will consist of news headlines and promotional pointers.

Channel Nine does not proposed to operate the digital screen and digital 'ticker' sign on a 24 hour per day, 7 days per week basis, but is seeking a flexible arrangement whereby operational hours will be governed by the nature of the material being shown. For instance, during a cricket broadcast, the screen will remain in use in until the conclusion of play at a minimum. As such Channel Nine has requested discretionary management of the 'on' and 'off' times of the digital screen and ticker display.

LEGISLATION / POLICY:

Legislation	<i>Planning and Development Act 2005</i> City Planning Scheme No. 2
Policy	
Policy No and Name:	4.6 – Signs Parliament House Precinct Policy

COMPLIANCE WITH PLANNING SCHEME:**Development Requirements**

The site is located within the City Centre Use Area of the St Georges Precinct (P6) under City Planning Scheme No 2 (CPS2). The site is also located within the Inner Precinct of the Parliament House Precinct and, therefore, also requires approval from the Western Australian Planning Commission under the Metropolitan Region Scheme.

The Statement of Intent for the St Georges Precinct states that the present skyline character of tall, slender, interestingly shaped towers, lighting and appropriate roof signs, will be maintained in any future development. The CPS2 Signs Policy sets out the requirements for the erection and management of signs on or adjacent to buildings within the city providing guidelines for their acceptable design and location. The proposal's compliance with the Signs Policy is detailed in the comments section of this report.

The Council, pursuant to Clause 43 of the CPS2, is to have 'regard' to the strategic and statutory planning framework when making determinations. Variations to the Signs Policy can be granted by an absolute majority decision of the Council, in accordance with Clause 47 of the CPS2 and provided Council is satisfied that:

- '47(3)(d)(i) if approval were to be granted, the development would be consistent with:*
- (A) the orderly and proper planning of the locality;*
 - (B) the conservation of the amenities of the locality; and*
 - (C) the statement of intent set out in the relevant precinct plan; and*
- (ii) the non-compliance would not have any undue adverse effect on:*
- (A) the occupiers or users of the development;*
 - (B) the property in, or the inhabitants of, the locality; or*
 - (C) the likely future development of the locality'.*

COMMENTS:**Signs Policy**

Under Policy 4.6 – Signs (the Policy) the proposed signs are classified as both horizontal signs and 'new technology' signs with third party advertising content. General performance criteria as well as specific design criteria are applicable as follows:

Signs Within Special Areas – St Georges Terrace

The Policy states that within the St Georges precinct Council will encourage signs that create an attractive daytime and evening atmosphere, express the character of the business and commercial environment, and enhance views of the city skyline. It is considered the proposed signs will not have a detrimental visual impact on the area and will encourage people to gather in the public plaza and bringing activity and vitality to the area.

Any signage within the area should also identify major tenants, building names and street numbers, and should be in keeping with the prestigious office environment. The signs will clearly identify the principal tenant of the studio building and associated offices on 251, 255 & 267 (Lots 10, 11 and 412) St Georges Terrace, Perth and will operate as an integral part of the Channel Nine operations on this site.

The Policy also states that illumination should be subtle and flashing signs will not be approved. The large LED screen, whilst not intended to be flashing, may at times display flashing images due to the screen airing an unedited version of what will be airing on Channel 9 television. It is recommended that condition be imposed on any approval granted requiring the illumination levels of the signs to comply with the Australian Standards: Control of the Obtrusive Effects of Outdoor Lighting (AZ4282-1997) and the maximum luminance of the sign being in accordance with the levels identified by Main Roads WA being daytime – 6000 cd/m², dawn/dusk – 600 cd/m² and night – 300 cd/m². A further condition can require that the digital ‘ticker’ sign is not to be flashing.

It is noted that the digital screen will be facing into the public plaza and not directly onto St Georges Terrace and while it will have visibility from the street it will be largely blocked by existing trees along St Georges Terrace. Given this, it is not considered the content or operation of the sign will a negative impact on the area.

Third Party Advertising

The Policy states that:

“Third party or general advertising will only be permitted where, having regard to the character of the area in which the sign is to be situated, the Council is satisfied that the visual quality, amenity and safety of the area will be enhanced, or at the very least, not diminished.”

It is considered that the signs will not negatively impact on the visual quality, amenity and safety of the area. The restriction of the third party advertising to only that which is airing on Channel Nine rather than general advertising is considered appropriate. It is recommended that a condition be imposed on any approved granted requiring the third party advertising content to be restricted to the display of Channel Nine Network free to air channels, station promotion products, services or events for the network located on the site.

New Technology Signs

Under the Policy, 'new technology' signs are only permitted within the Citiplace and Northbridge Precincts, with the most appropriate location considered to be within plazas or public spaces where they can be viewed by gathered or passing pedestrians. While the site is not located within these precincts the digital screen will front the 'plaza' landscaped forecourt of the studios which is intended for gathering of the public. The main audience of the sign is intended to be pedestrians and members of the public. As the primary purpose of the sign is to screen the broadcast of Channel Nine television station, the intention of the sign is not to provide general advertising (except for that shown in advertising breaks) rather to provide entertainment suitable to the public location and provide news headlines, so in this instance it is considered that the locational requirements can be varied.

Response to Location and Contribution to Local Character

All new signage in the city is required to respond to the local character of the street and the prevailing building style as well as making a positive contribution to its setting. Enhancement of the desired future environmental character of an area should also be a primary consideration when assessing the appropriateness of a new sign proposal.

The intended local character of this Precinct is that it will continue to function as the State's principal centre for business, finance, commerce and administration and the continuation of large scale development in this Precinct will reflect its high profile, its image as a group of landmark buildings and the predominance of the Precinct as the State's business heart. Building designs within the area will contribute to an interesting and comfortable pedestrian environment and provide for pedestrian shelter along with other elements, such as street furniture, planting and public art, defining an interesting promenade and reinforcing the vista to Barracks' Arch and Parliament House. The existing office building with its blank façade abutting the landscaped forecourt area does little to contribute to this character, with little interaction occurring with the street and landscaped area. The proposed signs are considered to add to the creation of a more "lively, colourful and stimulating environment" in this section of the street.

Variety and Interest

The Signs Policy recognises that signage can play an important role in the interest and appeal of a building or place, and as such the City supports variety over monotonous design. A sign should reflect the quality of the service or the merchandise that it is advertising, be appropriate to the building or site and aim to attract attention in a way which is well thought out and well designed.

The proposed signs will add visual interest to the building's blank western façade and new studio building. The proposed scale of the signs in relation to the building is not considered to be excessive. The display of the television programming is considered to bring interest and appeal to both visitors to the city and office workers particularly during lunch hours, to utilise the forecourt area in a relatively unused space along St Georges Terrace.

Community Expectations

The objective of the Signs Policy has been to ensure that the city is not detrimentally impacted upon by a proliferation or clutter of signage that is unsympathetic to the character of the city's precincts and buildings. Stringent controls on particular types of advertising signs, particularly those displaying third party advertising, have been relaxed in recent times, in some instances, in recognition of new advertising trends and technology. A review of the Signs Policy is currently underway to address these changes in expectations and various aspects of the policy which are now considered to be out-dated.

It is considered that given the location of a television filming studio on the site it would not be unexpected for a television screen being located on the site showing what is being aired on said station and this would generally meet community expectations for the city centre. Given the direction the screen is facing and that the screen is not clearly visible from a distance, visual clutter is not considered to be an issue.

Safety

A sign should in no way endanger the safety of the public and 'new technology' signs should not be able to be viewed by passing motorists for whom they may be a distraction and therefore a safety hazard. The content of 'new technology' signs may move but not flash or pulsate in a manner that is likely to cause a hazard or nuisance to motorists or the occupants of neighbouring properties.

The sign will be visible by motorists travelling east on St Georges Terrace and onto St Georges Terrace from Elder Street. As the sign is located mid-block it would not interfere with the operation or safety of the intersections at St Georges Terrace and Elder Street.

A traffic safety assessment provided as part of the application concludes that the signs would be considered to be a low risk rating for causing vehicle crash. The screen and news ticker are unlikely to cause a significant distraction to passing motorists using Malcolm Street, St Georges Terrace and Elder Street.

Design, Construction and Maintenance

Signs are required to be simple, clear and efficient with structural components and wiring concealed. The proposed ticker display sign will be attached to the canopy of the approved live studio and the digital screen will be affixed to the western façade of the building on-site and as such will be integral components of the buildings on-site. It is considered that a condition should be imposed requiring all supporting structures and services being concealed from view.

Design Guidelines/Policy

Parliament House Precinct

As the site falls within the inner Parliament House Precinct the application is required to be approved by both Council and the Western Australian Planning Commission (WAPC). The application has been forwarded to the WAPC and the City's determination will also be sent to the WAPC for their reference.

The Parliament House Precinct Policy states that there shall be a presumption against the use of illuminated signs visible from Parliament Hill and that all signs should be an integral part of the building and not freestanding attachments.

The proposed television screen will not be visible from Parliament House with the Barracks Arch, the proposed studio building and existing vegetation blocking the view of the screen (refer Schedule 1). It is considered that the signs will not result in any detrimental impact to views to and from Parliament House or to the character of the Parliament House Precinct and can be supported.

Conclusion

The proposed new technology signs are generally consistent with the requirements and intent of the CPS2, including Policy 4.6 – Signs, and the Parliament House Precinct Policy. The signs are considered to maintain visual interest and vibrancy to the adjacent street environment. Pursuant to Clause 47 of the CPS2, the proposal is recommended for conditional approval.

Moved by Cr Adamos, seconded by Cr Yong

That in accordance with the City Planning Scheme No. 2, Council APPROVES BY AN ABSOLUTE MAJORITY the application for two 'new technology' signs at 251-253 (Lot 10) St Georges Terrace, Perth, as detailed on the application form dated 15 December 2015 and as shown on the plans received on 18 December 2015 subject to:

- 1. all associated supporting structures, cabling, wiring and services being located subsurface and internal to the signs with final details being submitted to and approved by the City prior to applying for the relevant building permit;***
- 2. any third party advertising content being restricted to the display of commercial playback as contained within the live streaming of Channel Nine Network free to air channels, station or client promotion products, services or events for the television network located on the site;***

(Cont'd)

3. *the content of the signs shall exclude any symbols, graphics or text that could be mistaken for an instruction to drivers or any colours, shapes or lighting that could be mistaken for a traffic sign or traffic control signal, or a format normally used for traffic control or warning, incident or traffic management, or road safety or driver information messages, except where required by a public authority;*
4. *the signs complying with the relevant requirements of the Australian Standards: Control of the Obtrusive Effects of Outdoor Lighting (AZ4282-1997) and the maximum luminance of the sign being in accordance with the levels identified by Main Roads WA being daytime – 6000 cd/m², dawn/dusk – 600 cd/m² and night – 300 cd/m²;*
5. *the signs being designed with a default setting that will display an entirely black screen when no content is being displayed or when a malfunction occurs;*
6. *a management plan for the signs detailing the control of the content, illumination levels, management and maintenance of the signs being submitted to and approved by the City of Perth prior to applying for the relevant building permit; and*
7. *the applicant/owner of the sign exempting the City of Perth from any liability resulting from claims due to driver distraction caused by the sign, with the applicant/owner accepting all responsibility for any such claims.*

The motion was put and carried

The votes were recorded as follows:

For: Crs McEvoy, Adamos and Yong

Against: Nil

Meeting Note: The Planning Committee requested that more information regarding the audio of the proposed screens be presented to Council for consideration prior to a decision being made.

PL9/16 FINAL ADOPTION OF AMENDMENT NO. 33 TO CITY PLANNING SCHEME NO. 2 – SPECIAL CONTROL AREA – 942 AND 950 HAY STREET AND 33 MILLIGAN STREET, PERTH

BACKGROUND:

FILE REFERENCE:	P1031595
REPORTING UNIT:	Strategic Planning
RESPONSIBLE DIRECTORATE:	Planning and Development
DATE:	15 January 2016
MAP / SCHEDULE:	Schedule 3 – Summary of Submissions Schedule 4 – Scheme Amendment Report

A development application for a 20 level office development, 65 room boutique hotel and the conservation of and extensions to the Melbourne Hotel was approved by the Perth Local Development Assessment Panel on **17 July 2014**.

At its meeting held on **30 June 2015** Council resolved to initiate Amendment No. 33 to City Planning Scheme No. 2, refer it to the Environmental Protection Authority and publically advertise it.

Amendment No. 33 proposes to establish a Special Control Area over three separate lots, being Lot 651 (942) and Lot 802 (950) Hay Street and Lot 650 (33) Milligan Street, Perth to enable the Melbourne Hotel to be subdivided from the proposed office building site, while maintaining the integrity of City Planning Scheme No. 2 and the approval to commence development in terms of plot ratio and tenant car parking.

LEGISLATION / STRATEGIC PLAN / POLICY:

Legislation	Clauses 75, 81 and 84 of the <i>Planning and Development Act 2005</i> Clauses 56 and 57 of City Planning Scheme No. 2
Integrated Planning and Reporting Framework Implications	Corporate Business Plan Council Four Year Priorities: Perth as a Capital City S5 Increased place activation and use of under-utilised space 5.2 Develop a precinct and place management approach for the City.
Policy	
Policy No and Name:	City Centre Precincts 1 to 8 Plan

DETAILS:

The Amendment was referred to the Environmental Protection Authority (EPA) following initiation and the EPA subsequently advised that it considered that the Amendment should not be assessed under the *Environmental Protection Authority Act 1986*.

The Amendment was advertised for public comment from 13 October 2015 until 25 November 2015 as follows:

- notices were sent by mail to nearby landowners;
- a notice was placed in The Western Suburbs Weekly newspaper on 13 October 2015;
- a copy of the Public Notice was displayed on the Public Notices Board at the City of Perth Customer Service Centre;
- details of the Amendment were available for inspection at the City of Perth Customer Service Centre and Library; and
- details of the Amendment were displayed on the City of Perth's website.

One submission was received in relation to the Amendment from the State Heritage Office, which was supportive of the Amendment.

FINANCIAL IMPLICATIONS:

ACCOUNT NO:	CL 16201000
BUDGET ITEM:	Community Amenities – Town Planning & Regional Development – Other Town Planning
BUDGET PAGE NUMBER:	8
BUDGETED AMOUNT:	\$1,154,199 (this component is \$117,899)
AMOUNT SPENT TO DATE:	\$ 426,259 (this component is \$23,341)
PROPOSED COST:	\$ 1,000 (Public Notice and Gazettal)
BALANCE:	\$ 726,940

All figures quoted in this report are exclusive of GST.

If adopted by the Minister for Planning, public notices will be required to be placed in a local newspaper and in the Government Gazette. The costs associated with these will be recouped from the applicant.

COMMENTS:

Pursuant to Regulation 50(3) of the *Planning and Development (Local Planning Schemes) Regulations 2015*, Council is now required to pass a resolution either:

- (a) to support the amendment without modification; or
- (b) to support the amendment with proposed modifications to address issues raised in the submissions; or
- (c) not to support the amendment.

The Amendment will assist further development on the site and restoration and ongoing maintenance of the Melbourne Hotel. It will allow the Melbourne Hotel site to be subdivided from the proposed office building site, whilst preserving both the plot ratio and car parking allocation approved under the development approval for the site.

On this basis and given no objections have been received, it is recommended that the Amendment be adopted without modification.

Moved by Cr McEvoy, seconded by Cr Yong

That Council:

- 1. pursuant to Regulation 50(3) of the Planning and Development (Local Planning Schemes) Regulations 2015, adopts Amendment No. 33 to City Planning Scheme No. 2 without modification as detailed in the Scheme Amendment Report being Schedule 4¹;***
- 2. pursuant to Regulation 53 of the Planning and Development (Local Planning Schemes) Regulations 2015, forwards Amendment No. 33 to City Planning Scheme No. 2 and associated documents to the Western Australian Planning Commission for consideration and recommendation to the Minister for Planning; and***
- 3. pursuant to clause 56(5) of City Planning Scheme No. 2, adopts the amended Precinct Plan as detailed in Schedule 4, subject to the gazettal of Amendment No. 33 to City Planning Scheme No. 2.***

The motion was put and carried

The votes were recorded as follows:

For: Crs McEvoy, Adamos and Yong

Against: Nil

5.46pm The Manager Activity Approvals departed the meeting and did not return.

**PL10/16 HERITAGE RATE CONCESSION APPLICATION FOR
PROPERTY AT 45 WELLINGTON STREET, EAST
PERTH**

BACKGROUND:

FILE REFERENCE:	P1028425
REPORTING UNIT:	Arts, Culture and Heritage
RESPONSIBLE DIRECTORATE:	Economic Development and Activation
DATE:	11 January 2016
MAP / SCHEDULE:	Confidential Schedule 5 – Application (Distributed to Elected Members under a separate cover)

¹ Amended typographical error from agenda by changing “Schedule 3” to “Schedule 4”.

On 26 November 2014, the City of Perth (the City) received a HRC application from the owner of 45 Wellington Street, East Perth, however the City did not process the application because the required supporting documents detailing evidence of building insurance and pest control contract were not provided.

On 24 March 2015, the City advised the owner that the application was incomplete and that if the required documents could not be submitted the owner may request for the application for be considered by Council, given that approval would require a variation to Council Policy.

On 24 November 2015, the owner verbally requested that the application be determined by Council.

On 8 January 2016, the owner verbally advised that, whilst there is no formal pest control contract for the property, the property has been regularly treated for termites since occupied by the current owner (50 years). The owner has advised that the property is inspected annually for termites and that termite spray mixed with linseed oil and engine oil is applied every 4-5 years on all structural and non-structural internal and external timber, including under internal floor coverings and the pilings under the house.

On 12 January 2016, the owner supplied the City with a copy of the building insurance certificate.

Application Assessment

Other than the absence of the pest control contract, the application fully complies with Council Policy 9.2.

Whilst the HRC concession application for 45 Wellington Street, East Perth, does not comply with the Policy requirements to provide a pest control contract, it is the view of Officers that the owner has adequately demonstrated that comprehensive termite control is implemented at the property.

In addition, Officers have internally and externally inspected the property in 2014 as part of the owner's nomination to include the property in the CPS2 Heritage Register. Officers found no evidence of termite damage and concluded that the property was in good condition.

The property was also externally inspected by the City on 1 May 2015, as part of its annual heritage property condition reporting, and was found to be in good condition, subject to ongoing maintenance.

FINANCIAL IMPLICATIONS

In accordance with Council Policy 9.2, the concession will be equivalent to 10% of the general rates for the property, to a maximum of \$20,000 per annum with the minimum concession being equal to the minimum rate payment.

If the application is approved, the minimum concession which is equal to the minimum rate payment (for 2015/16 this figure was \$685) will be applied to the owner's rate notice until 30 June 2017, as per the HRC Council Policy 9.2.

Moved by Cr McEvoy, seconded by Cr Yong

That Council:

- 1. notes that the Heritage Rate Concession application for 45 Wellington Street, East Perth, dated 26 November 2014, does not comply with Council Policy 9.2 – Heritage Rate Concession, specifically clause 2.4 which requires the applicant to provide evidence of a current pest control contract;***
- 2. notes that the current owner of property has occupied and suitably² maintained the property, including annual pest maintenance (termite spraying), for 50 years;***
- 3. approves the subject application given that the intent of clause 2.4 of Council Policy 9.2 – Heritage Rate Concession has been addressed, as outlined in (2) above.***

The motion was put and carried

The votes were recorded as follows:

For: Crs McEvoy, Adamos and Yong

Against: Nil

**PL11/16 WATERBANK INFRASTRUCTURE AND PUBLIC
DOMAIN WORKS – 3 (LOT 502) TRINITY AVENUE,
EAST PERTH**

BACKGROUND:

SUBURB/LOCATION:	3 Trinity Avenue, East Perth
FILE REFERENCE:	DA-2015/5464
REPORTING UNIT:	Development Approvals
RESPONSIBLE DIRECTORATE:	Planning and Development
DATE:	18 January 2016
MAP / SCHEDULE:	Schedule 6 – Location Map
LANDOWNER:	Metropolitan Redevelopment Authority
APPLICANT:	TPG Town Planning, Urban Design and Heritage

² Amended typographical error from agenda by changing the word "suitability" to "suitably".

ZONING: (MRS Zone) Redevelopment Scheme/Act Area
(City Planning Scheme Precinct) Langley (P12) and
East Perth (P15)
(City Planning Scheme Use Area) N/A

APPROXIMATE COST: Not specified

SITE HISTORY:

The four hectare 'Waterbank Precinct' (the precinct) situated on the eastern edge of the city is bound by Trinity College to the north, the Swan River to the east, the Causeway interchange to the south and the Western Australian Police site to the west. The Precinct forms part of the Metropolitan Redevelopment Authority's (MRA) greater Riverside Project Area.

At its meeting held on **11 August 2015**, Council considered the first stage of subdivision of the Waterbank Precinct and resolved to advise the MRA of its in principle support subject to conditions and the submission of additional details and information. The Minister for Planning (on the advice of the MRA) has yet to determine the subdivision application.

In September 2015, the MRA referred to the City for comment a development application for a temporary sales office and carpark within the Precinct. The City under Delegated Authority on 16 October 2015 advised the MRA of its concerns with regards to the location of the proposed temporary sales office. In addition, the City recommended a series of conditions should the MRA resolve to approve the application. The MRA has yet to determine the development application.

At its meeting held on **3 November 2015**, Council considered the first private realm development within the Precinct for a mixed use building on 'Site G' and resolved to advise the MRA of its in principle support subject to relevant design revisions and conditions. The MRA has yet to determine the development application.

In December 2015, the MRA referred to the City for comment a subdivision application for the second stage of subdivision of the Precinct. Council will consider the application at a future meeting.

DETAILS:

Approval is sought for the design and construction of the entire infrastructure and public domain components associated with development of the Waterbank precinct. The applicant advises that the proposal is for the creation of a high quality public domain that will service future residents, workers and visitors alike through the provision of a variety of spaces and experiences to cater for passive recreation, active sport, water sports, swimming, casual coffees and fine dining.

The proposed public realm is structured and generally described by the applicant as follows:

- The extension of Hay Street to the river with a public square ('Waterbank Square') generating a focal point and activity hub at the eastern end of the precinct. The square will transition from a shared zone vehicle turn around and

drop off area to a tiered boardwalk where it interfaces with the Swan River. The Waterbank Square itself will be a flexible event space with formal landscape arrangements and feature tree planting.

- A main arrival gateway at the north-western corner of the precinct marked with a public plaza providing an urban environment leading into the Waterbank development with provision for an entry statement and public art. This space will be planted with deciduous trees and will incorporate rain gardens with low seating walls to offer a space for pedestrians to sit and interact.
- A large central park framed by future built form and accessible to all. The space will be surrounded by primarily residential uses to the south and north-east and commercial uses to the north-west and will connect with the Swan River via a new beach front. This space will support active sports and passive recreation uses.
- Riverfront promenade and jetty areas incorporating a lower level timber boardwalk to the water's edge with seating and an upper level promenade with the allowance for alfresco seating.
- A river foreshore providing a variety of activities including a path and cycle network, BBQ facilities, exercise equipment and a soft riverine edge to the river.
- An internal road network that has been arranged in a way that preserves key and secondary view corridors to the river and back to the city centre.
- A new parking area to be located in the north-eastern part of the precinct serviced by a 'spur' road which deviates from the main Hay Street alignment.
- A range of soft and hard landscaping and promenade treatments to the edge of private development sites within the precinct.
- Servicing and infrastructure works including a series of trenches and excavations to extend the utility network throughout the public domain, such as gas, water reticulation, drainage/stormwater, telecommunications, power, fibre optic cables and closed-circuit television (CCTV).

Specific details and aspirations for the main public realm components and the related landscaping, materials and finishes, public art, transport, servicing and infrastructure elements of the development are further outlined by the applicant as follows:

Waterbank Square and Boardwalk

Located at a prime waterfront position at the termination of the Hay Street axis, 'Waterbank Square' will be the civic heart and primary public space of the Waterbank precinct.

Defined by proposed active built edges and fronted by the river, Waterbank Square will have a distinct identity that promotes riverside access. It will be a formal space

with an integration of seating, trees, and alfresco dining within a flexible public open space that can be used for community events such as markets and performances.

Towards the river, the character of the square will become more relaxed with lounging opportunities built into the boardwalk decking and access to the jetty and water based activities.

Hardscape paving will transition from a feeling of an urban into a more natural riverine feel with a change in colour. The use of timber in both furniture and decking will also be used for the creation of a riverine/natural feel in and around the Waterbank square.

Seating walls are designed alongside level changes and rain gardens.

A feature mature tree will be positioned within the square for instant impact while offering a way finding element. Feature lighting throughout the square allows for activation at all times of the day.

The Hay Street axis will be emphasised and strengthened by continuing the Hay Street alignment over the water on a jetty. This vista down Hay Street will terminate on this jetty.

The riverfront promenade and jetty will provide the opportunity for people to get close to and enjoy the natural amenity of the river's edge. Multiple seating locations will be created for the public to sit and interact with activities within the square and adjacent river.

The boardwalks and jetty offer a variety of activities, including strolling, sitting, bird watching, alfresco waterfront dining and swimming.

Hay Street Corner Urban Plaza

'Hay Street corner' is proposed as the entry point to Waterbank, with hardscape treatments that continue the precinct design principles, establishing the entry as an urban space. The use of paving and a strong axis of deciduous trees offering shade and protection will direct pedestrians into the 'heart' of the Precinct, while the continuation of street trees along the extension of Hay Street will lead pedestrians towards Waterbank Square. The corner will also be designed to accommodate a public art piece.

A series of 'meeting rooms' will be created in and around the rain gardens, fed from the future commercial buildings, with low seating walls and furniture offering informal multiple locations for pedestrians to meet.

Waterbank Central Park

The central park will be a significant open space that is accessible to all and will connect with a new beach along the riverfront. The overall quality of the central parkland will transition from an urban character at the western edge adjacent to the proposed commercial buildings to a riverine and natural character along the river's

edge. The overall intention for activities within the central parkland is to transition from a quiet, more passive space in the west, such as yoga or eating lunch under the trees, to a mix of active and passive recreational spaces in the east, that might include picnicking, beach volleyball, kicking a ball on the grass, playing on the play equipment, or engaging with the waters edge. Two water cleansing swales will border the central multifunctional turf space. The northern swale incorporates nature based play equipment for use through the majority of the year including public art elements.

Access along the river's edge is designed to encourage locals and visitors to stop, rest and watch activities along the newly created beaches. Shelters provide protection from the elements and mature tree transplants will offer an instant impact within the central park.

Materials, Finishes and Colours

Palette

The hardscape areas are designed to reinforce the concept of a more urban character towards the western portion of the site and Hay Street, and to transition to a more natural character towards the river edge. The hardscape selected reflects and helps establish the hierarchy of streets, paths and urban spaces across the precinct. Materials used are also to be consistent with the City of Perth and MRA guidelines and preferences.

Road Hierarchy

The Hay Street extension that links Waterbank to the water in the east and the Perth CBD in the west, is to be read as the main urban boulevard into the site. The materials used for the Hay Street extension are black asphalt road surface, large format paved pedestrian paths, and trafficable pavers within drop off zones.

The secondary internal and shared roads are to characterise a traffic calmed environment that prioritises the pedestrian and discourages through vehicular traffic through the site. The internal roads are typically characterised by asphalt for the road surface, urbanstone pavers and trafficable urbanstone pavers for the smaller internal/drop off roads.

Path Surfaces

Two different paving arrangements are proposed, urbanstone pavement bordering the Hay Street extension and internal roads, and the other granite pavement mix used to highlight Waterbank Square and the adjoining proposed alfresco promenade.

The timber boardwalks are proposed as hardwood decking.

All principal shared paths through the precinct are to be red asphalt with kerbing to match into the existing principal shared paths along the foreshore. Where the principal shared interfaces with main pedestrian areas, the principal shared path will give priority to the paved pedestrian surface to ensure safe shared zones.

Other paved footpaths near the river's edge consist of exposed aggregate finish concrete highlighting the colours of the foreshore. Pedestrian crossing tactiles are provided at pedestrian crossing and intersection. Tactile indicators are provided along pathways where required.

Wall Treatments

Various wall treatments are proposed throughout the precinct to provide interest and a high quality built form to each of the public spaces. Three main wall treatments are proposed being white precast concrete walls, gabion walls with recycled building rubble infill, and white precast concrete tiered walls.

Balustrades are provided along each decked boardwalk and are constructed from steel with a timber infill.

Furniture

The selected furniture palette will respond to both the urban and river context in which the Waterbank precinct is located. For Hay Street and urban parts of the site, the furniture should be selected from the proprietary palette. Furniture within Waterbank square and alfresco areas shall be bespoke furniture made from timber and steel, designed to be in keeping with the shelters, play structures and artwork.

The proposed furniture for the precinct includes but is not limited to shelters, BBQs, an outdoor shower, rubbish bins, bench seats, picnic seating, bike racks, fitness equipment, bollards, ping-pong tables, drinking fountains, and handrails.

Lighting

The lighting strategy is intended to give a high quality ambience throughout the scheme. A variety of lighting types will set the mood, and define the project while reinforcing the distinctiveness of significant spaces and streetscape.

Adequate lighting levels are also necessary to create a safe environment for pedestrians at night and to comply with Crime Prevention through Environmental Design (CPTED) principles and ratings.

Several types of lighting are proposed being post lighting, tree and feature up-lighting, bollards, under deck edge lighting strips, under bench/table lighting strips, under balustrade lighting strips, catenary lighting, façade lighting, gateway lighting, and lighting beacons for major art works.

Public Art

A Public Art Strategy has been prepared for the Waterbank project area by art consultant FORM. The Strategy provides an overview of how a well considered Public Art Strategy can act as a mechanism for cultural exchange, creative expression and place enhancement as part of the Waterbank development. The proposed public artworks for Waterbank are separated into two phases with the following being proposed for Phase 1:

- Waterbank Square Lighting – an ephemeral, lighting based artwork which will be suspended above the Civic Plaza;
- Swale Artwork – a clustering of sculptural artworks integrated along the length of the bio-filtration swale to create a sense of discovery and play;
- Boardwalk Seating – bespoke sculptural seating along the pedestrian boardwalk; and
- Pier Artwork – design works for the Pier Artwork which is proposed to be a large scale, standalone artwork to be commissioned for Waterbank’s pier and is proposed to stand as an iconic beacon for the precinct.

The proposed Phase 2 public artworks are:

- Pier Artwork – a large-scale, standalone artwork to be commissioned for Waterbank’s pier and will stand as an iconic beacon for the precinct.
- Precinct Entry Artwork – a large-scale standalone artwork to be commissioned for the main entry into Waterbank;
- Boardwalk Entry Artwork – two medium-scale standalone artworks to be commissioned at each entry point along the pedestrian boardwalk;
- Playscape – a series of small and medium scaled sculptural playscapes to be commissioned for a range of areas throughout the Waterbank precinct;
- Residential Entry Artwork – a medium scale standalone artwork to be commissioned for the entry into the residential zone of Waterbank; and
- Art and Cultural Content for Precinct App – a mobile application that offers the opportunity for the user to access interpretive information about the Waterbank precinct.

Vegetation and Tree Planting

The vegetation and tree planting strategies align with the project vision of urban in the west transitioning to natural along the river. An urban interface is proposed along the project boundaries, a riverine quality along the length of the river, and a parkland quality in the central parkland.

Key design drivers in the choice of planting within the Waterbank public realm precinct include:

- Indigenous species;
- Amenity;
- Seasonal variation;
- Assists way-finding;
- Destination markers;
- Provision of shade (and reduction of the heat island effect); and
- Outlook from buildings.

Trees have been selected to continue an urban feel on entering the precinct with a consistent row of trees planted along the Hay Street extension at regular intervals to form a visual axis. Along the internal streets and plaza a mix of deciduous and

evergreen species have been selected to allow for shade in the warmer months and light during the winter. Mature transplants are chosen to enhance the parkland feel to the corner of the precinct while local and endemic species are situated along the river and swales.

Water Sensitive Urban Design (WSUD) strategies are to be employed to improve water quality while ensuring appropriate nutrient stripping of stormwater prior to entering the river. Water is to be celebrated on the site through WSUD principles integrated with rain gardens, swales and riverine vegetation. The overall site design principles include:

- Designed around sustainable water detention and disposal;
- All stormwater from future buildings and public realm to be captured with rain gardens and swales, filtered and stripped of all required nutrients;
- Appropriate vegetation to be selected to filter the required nutrients prior to storm water entering the river; and
- Increase sustainability awareness through interpretive information within public art and/or signage across the site.

Transport, Parking and Access

The Waterbank development is proposed as a transit oriented development (TOD), which will have many advantages in reducing the dependence on and use of car travel. These advantages are considered to outweigh any issues relating to local congestion, which can be managed. Traffic volumes are observed as heavy on the major roads around Riverside, and congestion is experienced during peak periods, which is the same as many other entry points into Perth City.

Vehicle, Pedestrian and Cycle Access

The recreational cycle network and Principal Shared Path is being routed directly adjacent through Waterbank, encouraging cycling as an important mode of transport. The existing cycle and pedestrian links to the site are excellent and provide an opportunity for improvement or strengthening through clever and innovative design. The existing continuous shared path that runs around the Swan River will be retained and routed through the Waterbank site, while sport cyclists and commuters will be directed to the west of the development.

Key features of the proposed street network are:

- Extension of the local cycle network and footpaths through the development to promote and provide continuity for cycling and walking;
- Street design to promote cycling and pedestrian priority;
- Maintained access to Trinity College;
- Parking provision that will not dominate streetscapes; and
- Promotion of walking and connected pedestrian access to the Perth CAT and free transit zone.

Car Parking

A precinct wide approach to parking has been adopted for the Waterbank precinct. It is important to apply TOD based principles to the provision of parking within Waterbank and Riverside more generally. The proportion of traffic into the Perth City by car is decreasing as is the proportion of traffic generated by residential and non-residential development in the city. A major implication of this is that the level of parking required in developments such as Waterbank can be less than that previously required. A total of 180 on-street parking bays are proposed to be provided.

Servicing and Infrastructure

The subject site is well serviced by all utilities, however upgrades are proposed as part of this application, including the excavation of a series of trenches and other excavations to extend the utility network, including stormwater, throughout the public domain.

The overall servicing strategy has been developed to optimise the delivery of infrastructure for both Stage 1 and 2 relating to this development application. All services have been designed in accordance with authority standards and prior consultation.

Offsite works including water and wastewater will be constructed in Stage 1 as these are required to de-constrain development requirements. This includes the offsite sewer crossing the Causeway / Adelaide Terrace along with water main upgrades in Hay Street and Plain Street. The internal water and wastewater covering both the Stage 1 and Stage 2 areas will also be constructed in Stage 1 works to mitigate the impacts of future excavations within road reserves and associated pedestrian / traffic disruption, whilst also minimising redundant works.

Power will be constructed in two stages based on the anticipated development roll out. Where practicable, the design has allowed for a number of services to enter the site via a dedicated 'service corridor' located between Building E and F. Alignments for all services will be in accordance with the Utility Providers Code of Practice.

Water Reticulation

Water reticulation for Waterbank has been assessed in accordance with Water Corporation Design Standard DS 63 – Water Reticulation Design and Construction Requirements for Water Reticulation Systems up to DN250. Existing water services are proximate to the site including an existing 100 diameter main in Hay Street.

Based on consultation with the Water Corporation the existing 100 diameter main will require upgrading to a 250 diameter main from the intersection of Hay Street/Erskine Link to the proposed intersection of Hay Street / Road 1. From the intersection of Hay Street / Road 1 a new 200 diameter loop main is then constructed to service the site.

The 200 diameter main is predominantly contained within the road reserve of Road 1 with an easement through the Public Open Space (POS) required to create the loop. At the request of Water Corporation, an additional minor network upgrade is also

required in Plain Street between Forrest Avenue and Nelson Crescent to connect a link in the system.

Wastewater

Wastewater for the development has been designed in accordance with Water Corporation Design Standard DS 50 – Design and Construction Requirements for Gravity Sewers DN150 to DN600. All internal mains and lot connections have been designed as 225 diameter mains. The outfall for the site is located between Building C and D, crossing the Causeway and Adelaide Terrace and connecting into the existing gravity system located in Ozone Reserve off Adelaide Terrace. This system ultimately gravitates towards the Adelaide Terrace Pump Station. The crossings of both the Causeway and Adelaide Terrace will be constructed via trench less techniques to minimise disruption of traffic.

Power

The existing Western Power infrastructure surrounding Waterbank consists of an 11kV underground HV and LV network, with feeders in the area originating from the Forrest Terrace Zone Substation. Power conduits were installed along the eastern side of Trinity Avenue to accommodate new feeders to Waterbank. For Western Power to provide clearances each freehold lot will be serviced with an authority point of connection via the installation of underground cables and above ground distribution equipment. The equipment is expected to be installed within the developed lots as an extension of the road reserve though final design outcomes remain subject to further design development.

Lighting

The lighting to the new internal roadways and carparking within Waterbank will be designed to meet the levels of performance outlined in Australian Standard 1158.3.1:2005 Lighting for roads and public places: Part 3.1: Pedestrian area (Category P) lighting – Performance and Design requirements, and Part 1.1 (Category V) lighting Performance and Design Requirements. The City of Perth will ultimately determine the level of lighting to be provided upon road classifications.

Communications

Pit and pipe infrastructure will be provided to enable a service provider to provide fibre optic cables to the lot boundary.

Urban Water Management and Drainage

An Urban Water Management Plan (UWMP) for the Waterbank Precinct has been prepared and is outlined as follows.

Stormwater Management

The stormwater management system has been designated to comply with the City of Perth's Construction Note 2.1 – Stormwater Drainage Design (City of Perth, 2013) as

well as the requirements of Better Urban Water Management (Western Australian Planning Commission, 2008).

1 Year Average Recurrence Interval (ARI) Event

- Runoff from residential and commercial buildings will be connected to rain gardens or in the central POS basins for treatment and infiltration.
- Runoff from roads and car parks will drain to tree pits or bioretention basins for treatment and infiltration.
- Runoff from footpaths and plaza areas will drain to tree pits, rain garden, bioretention basins, or soakwells for treatment and infiltration.

20 Year ARI Event

- Flows exceeding the infiltration capacity of rain gardens will drain via pits and piped culverts to bioretention basins, or the Trinity Avenue trunk pipeline.
- Flows exceeding the infiltration capacity of tree pits will bypass to either stormwater pits or bioretention basins before discharging to the Swan River.
- Bioretention basins will drain to the Swan River via outlet pits and headwall at flows not exceeding the overall site discharge allowances.
- Overall Waterbank site discharge will not exceed allowable discharge in accordance with City of Perth Guidelines as applied for the precinct.

Greater than 20 Year ARI Event (up to 100-year ARI Event)

- Roads and POS are graded to convey surface water via overland flow for more severe storms, directing floodwaters to the bioretention basins, which are designed to detain 100 year ARI at a maximum depth of 0.7 metres.
- Water overtopping rain gardens will be controlled to discharge over predefined weirs within the structure such flows enter into the downstream drainage network with minimal risk to public safety.
- All habitable building pad levels to be at 3.1 metres AHD at least 0.5 metres minimum above the future 2110 Swan River 100 year flood event and the localised 100 year ARI event.

Stormwater Discharge Quality

There are multiple objectives and targets for stormwater quality at the site. As a general guiding principle, the Waterbank development will maintain surface and groundwater quality at pre-development levels and where possible, improve the quality of water leaving the development area.

Groundwater

The finished ground levels at the Waterbank site are typically between 2.5 metres AHD and the groundwater is expected at between 0.5 metres AHD and 1 metre AHD. The expected separation between the finished ground level and the groundwater will be greater than 1.2 metres, mitigating risks of waterlogging. The pre-development

groundwater recharge will be maintained through the use of various infiltration measures. The treatment of surface water prior to infiltration will maintain or improve groundwater quality.

LEGISLATION / POLICY:**Legislation**

Metropolitan Redevelopment Authority Act 2011

Metropolitan Redevelopment Authority's Central Perth Redevelopment Scheme

Policy

Policy No and Name: Metropolitan Redevelopment Authority 's Riverside Master Plan 2008

Waterbank Precinct Design Guidelines 2015

COMMENTS:**Public Domain and Infrastructure**

The configuration and layout of the public realm, the subject of this development application, has been guided by the associated subdivision applications for the Waterbank Precinct and more generally by the MRA's master planning and design guidelines documents. In its consideration of the first stage of subdivision, Council identified a number of fundamental issues which, if not resolved during determination of the application by the Minister for Planning (on advice of the MRA), have the potential to undermine the optimum design and performance of the precinct's public and private realms.

Noting the subdivision applications are subject to a separate approval process, the focus of Council's consideration in this case is on the physical development and treatments of all public areas and linkages and not on their spatial layouts or dimensions. In addition, it is considered important in the interests of efficiency and effectiveness to avoid duplicating the issues and conditions outlined during the subdivision assessment process. Consideration of the development of the public realm will therefore, be focussed on those matters not previously considered and any reiteration of issues will be limited to fundamental concerns.

Given the MRA has responsibility for determining the development application, the Council's role in this case is to provide comment and draft conditions to the MRA for its consideration. The importance of Council's role in this process is paramount given the City will be the ultimate recipient and custodian of the precinct's public domain areas and associated infrastructure.

In accordance with the above, the City has assessed the proposed development application in the context of the MRA's guiding documents and balanced consideration of its role as the future responsible authority for the precinct. Whilst the design of the development is generally in keeping with MRA's overall vision for the Precinct and can be supported, the following specific issues have been identified and are either recommended to be conditioned as part of any development approval by the MRA or required to be resolved to the City's satisfaction prior to the application being determined.

Design of Services and Public Facilities

The standard position of the City is that all service related infrastructure in both the private and public realm should be integrated into the design of a development or be screened from view in order to minimise their impact on the aesthetic quality of the built and street environment. An above-ground Western Power transformer is proposed to be located at the end of the access road that separates Sites C and D. Given the potential prominence of the transformer in this location, it is recommended that an alternative placement be required to preserve the future amenity of the surrounding development.

The location of the proposed public toilets and shower/change facilities to the west of the central public open space area is questionable noting its distance (approximately 140 metres) from the future public beach area. It is therefore recommended that in order to maximise potential use and provide for improved accessibility, the facility be relocated closer to the public beach. Additionally, provision should be made for future integration of these facilities at the ground floor level of future development within Sites B or J, which is foreshadowed in Section 5.2.6 of the Waterbank Precinct Design Guidelines. Management and maintenance arrangements shall be subject to separate negotiations between the developer, the MRA and the City.

The requirement for an open 'service yard' of the scale proposed, located between Sites K and L, is unclear, particularly as the future use of the proposed building on Site L has not been determined. Given exposed service yards are generally not supported by the City, it is considered that future servicing arrangements can be catered for in manner which is less visible within the urban context. It is recommended an alternative design be prepared for this area.

The applicant submitted separate preliminary universal access and CPTED reports in support of the application and overall design of the public domain and related infrastructure. The reports provide a series of recommendations in relation to the detailed design of the development. It is therefore considered critical that evidence of the applicant's design response to both the universal access and CPTED reports be submitted City's consideration and approval prior to the commencement of works.

Transport

As previously identified in Council's consideration of the Waterbank Subdivision Stage 1 at its meeting held on **11 August 2015**, the proposed parking area located at the termination of the Trinity Avenue extension area is not supported by the City. The requirement for the parking area has not been adequately demonstrated and noting the development has been designed in accordance with 'Transit Orientated Development' principles, it is recommended the area not form part of any approval by the MRA.

Whilst the concept of providing a centralised cycle path to provide for convenient access through the site is noted, the proposed shared path which traverses through the mid-section of the central public open space is not supported. The concerns related to the effective 'splitting' of the central open space area and introducing a barrier to users of the site, in addition to potential conflicts and safety issues with

cyclists and pedestrians within the area. An alternative approach is therefore recommended with the primary shared path being redirected around the perimeter of the site or another acceptable route that minimises potential conflict and retains efficiency of movement.

Civil Infrastructure and Services

The proposed stormwater management system for the development uses the principles of water sensitive urban design and is generally supported by the City despite its alternative arrangements compared with existing systems within the City. In order to ensure the long-term effectiveness of the proposed system, it is recommended that a management plan, including an extended monitoring program to be undertaken by the developer, be submitted for the City's approval. This is of particular importance given the City will be the ultimate custodian of the alternative bio retention infrastructure.

A range of paving materials is proposed in order to add interest and vitality to the hardscape environment of the development. Whilst the purpose of such a range is noted it is considered that the paving materials palette should be simplified and consolidated to provide for greater integration with the existing City environment. It is recommended that non-standard or alternative paving materials be limited to specific public interest zones within the development such as 'Waterbank Square'.

Future maintenance of the proposed boardwalk raises potential concerns given the unique method of construction and materials being proposed. It is therefore recommended that final details of proposed maintenance access for the boardwalk form the landward and/or river side be submitted for the City's consideration and approval. In addition and noting the City will be the ultimate custodian of the boardwalk and all related or similar elements of a structural nature, it is recommended that independent certification be provided prior to installation to the City's satisfaction.

Landscaping

The proposed boulevard design approach for the Hay Street extension area is noted however, it is considered that the trees proposed within the central median not form part of any approval. One of the key principles of the Waterbank Design Guidelines is to maintain the key vista from the city to the river. The use of mature trees within this location will be contrary to this vision and is therefore not supported.

An ongoing issue for the development that has not been resolved to date relates to an approved irrigation source for the proposed landscaped areas. It is therefore recommended that the applicant be required to submit final details of any proposed irrigation source and on-going access to ground water supply/s for the establishment and maintenance of all planted and turfed areas. This shall be required prior to the commencement of works for the development given its fundamental to the success or otherwise of the development.

The alternative bio-retention stormwater system proposes the potential use of scheme water to 'top up' landscaped areas within the system during drought periods.

This is not supported on the basis of self-sustainability as the system should operate effectively independent of any alternative water sources. It is recommended that the use of reticulated water for irrigating or supplementing water supply for landscaping elements not be permitted with details of the final design and year round operation of the system being approved in consultation with the City prior to the commencement of works.

It is noted that landscaping areas are proposed directly adjacent to future private development sites. In order to ensure suitable levels of permeability and interaction between future buildings and the streetscape, it is recommended that all such landscaped areas be designed with low-lying and suitable plant species to retain long term visibility.

Public Art

Public art forms an important element of the development and a Public Art Strategy has been prepared in support of the proposal. Given the potential ambiguous nature of public art concepts, it is considered that final details of all proposed art for the various locations within the development be designed in consultation with the City with a costed detailed Public Art Implementation Plan being submitted. The Plan shall include costs, asset management and a maintenance plan across all lifecycle phases with provision for the City to provide comment on the design vision, theming and brief and also be represented on the appropriate selection panel.

Place Activation

A draft Place Activation Plan has been provided in support of the development application. The Plan is aspirational in nature and provides guidance with regards to the potential for the site to accommodate events and uses within the public spaces for the benefit of the wider community. In order to provide for greater certainty and practicality, it is considered that a final Place Activation Strategy and fully costed and detailed place activation implementation plan be submitted to the City for approval. Such a strategy and plan should include activity levels and subsidies, and transition planning leading up to and post-handover to the City including strategies to achieve self-sustainability.

Memorandum of Understanding and Agreement

In accordance with the provisions of the Memorandum of Understanding between the City and MRA (5 August 2014) and the Riverside Project Agreement for Public Asset Design, Approval, Development & Handover between the City and MRA (30 July 2015), the developer (Lendlease) has submitted an 85% detailed design package to the City and MRA for review. The review process is separate to the development application referral process however, they are interrelated noting both relate to the design and construction of all the public domain areas and associated infrastructure within the Precinct. For the purposes of assessment and comment on the details and plans submitted as part of the subject development application, an effort has been made to distinguish between the conceptual and town planning/urban design aspects of the proposal and those of detailed design matters. Therefore, this report has focused on higher level planning and design matters that are relevant to the

development application, whereas the City's separate review of the 85% detailed design package will focus on the City's detailed construction, maintenance and asset handover requirements.

Conclusion

The works involved in the delivery of the Waterbank Precinct public domain and infrastructure provide a consistent approach to the Riverside Master Plan and help to achieve the key elements of the plan by providing the necessary activity areas and infrastructure to provide a significant new urban waterfront precinct on the eastern edge of the City. The public realm has generally been designed to a high standard and will provide future residents and the community with facilities that achieve a number of desired urban outcomes.

It is recommended that the MRA be advised of the City's support for the development subject to the issues identified within this report being addressed by way of conditions on any development approval or subject to further details being provided to the City's satisfaction prior to any approval being issued by the MRA.

Cr Adamos disclosed an impartiality interest in this item (detailed at Item PL6/16).

Moved by Cr Adamos, seconded by Cr Yong

That:

- 1. the Metropolitan Redevelopment Authority be advised that Council supports the application for the proposed infrastructure and public domain works of the Waterbank development within the Riverside project area at 3 (Lot 502) Trinity Avenue, East Perth as detailed in the application received on 18 November 2015 and as shown on the plans received on 18 November 2015 subject to:***

Design

- 1.1 the development being undertaken generally in accordance with the plans and documents attached to this application, final details of which are to be submitted to, and approved by, the Metropolitan Redevelopment Authority, in consultation with the City, prior to the commencement of works;***

(Cont'd)

- 1.2 all drainage, roads, footpaths, verges and kerbs, paved and landscaped areas, public realm furniture, lighting and other features in the public realm being designed and constructed in accordance with the City of Perth Design and Construction Notes, specifications and applicable Australian Standards, with any proposed variations or alternative designs being designed in consultation with the City;**
- 1.3 the proposed Western Power transformer located at the termination of the access road between Sites C and D being relocated or placed underground to minimise its impact on the public realm. Alternatively details of suitable screening being prepared in consultation with the City and being submitted to and approved by the Metropolitan Redevelopment Authority;**
- 1.4 the proposed public toilets and shower/change facilities within the western portion of the central public open space area being relocated closer to the public beach with provision being made for future integration of the facilities at the ground floor level of the future development within Sites B or J in accordance with Section 5.2.6 of the Waterbank Precinct Design Guidelines, with management and maintenance arrangements to be subject to separate negotiations between the developer, the Metropolitan Redevelopment Authority and the City;**
- 1.5 the proposed service yard located between Sites K and L being redesigned to reduce its public visibility noting the existing configuration is not in keeping with its urban context;**
- 1.6 evidence of the design response to the accessibility report prepared by O'Brian Harris Access on 25 August 2015 being to the City's satisfaction prior to commencement of works in relation to the public domain and infrastructure;**
- 1.7 evidence of the design response to the Crime Prevention Through Environmental Design Review report prepared by Jacobs on 15 December 2014 being to the City's satisfaction prior to commencement of works in relation to the public domain and infrastructure;**

(Cont'd)

Transport

- 1.8 all works related to the road widening and parking area proposed as part of the Trinity Avenue extension not forming part of the approval until such time that its purpose is suitably demonstrated to and supported by the City;**
- 1.9 footpaths having a minimum obstacle free dimension width of 1.5 metres;**
- 1.10 the shared path being designed and constructed with a minimum width of 3 metres, to integrate with the broader City cycle network and to align with the City of Perth Cycle Plan, inclusive of user advisory signage;**
- 1.11 the shared path alignment through the central public open space area being relocated and/or redesigned to an alternative route which provides for suitable cyclist movement through the development without impacting on the safety and functionality of the core area of open space within the development, with details of the new alignment being prepared in consultation with the City;**
- 1.12 a Way-finding Signage Strategy being prepared in consultation with the City and being submitted to and approved by the Metropolitan Redevelopment Authority, prior to the commencement of works;**
- 1.13 crossovers, driveways, car parking, vehicle manoeuvring spaces and loading/unloading areas within the public domain being designed, constructed, sealed, kerbed, marked and maintained in accordance with plans approved at the final working drawing stage in consultation with the City and to the satisfaction of the Metropolitan Redevelopment Authority;**
- 1.14 a final Traffic and Car Parking Management Plan, assessing traffic movements and detailing proposed methodology to minimise impacts on the local and wider street network in terms of pedestrian, cycle and vehicle safety, congestion and flow, emergency services access, being prepared in consultation with the City and being submitted to, and approved by the Metropolitan Redevelopment Authority prior to the commencement of works;**

(Cont'd)

- 1.15 a Road Safety Audit, including a finalised Corrective Action Report, being provided at working drawing stage in consultation with the City and to the satisfaction of the Metropolitan Redevelopment Authority;**

Civil Infrastructure and Services

- 1.16 all services and service related infrastructure and hardware forming part of the integral design of the development of the public domain to minimise any detrimental impact on the architectural quality of the streetscape and on neighbouring future private lot developments, details of which are to be submitted to, and approved by the Metropolitan Redevelopment Authority, in consultation with the City, prior to the commencement of works;**
- 1.17 independent structural certification for all structural elements being provided to the Metropolitan Redevelopment Authority and the City prior to installation;**
- 1.18 an acid sulphate soils self-assessment form and, if required as a result of the self-assessment, an acid sulphate soils report and an acid sulphate soils management plan being submitted to and approved by the Department of Environment Regulation before any subdivision works or development are commenced. Where an acid sulphate soils management plan is required to be submitted, all subdivision works shall be carried out in accordance with the approved management plan;**
- 1.19 final details of the design of public seating, street tree grates and the location and design of public bins to suitably mitigate the potential for litter build up and damage, being prepared in consultation with the City and being submitted to, and approved by the Metropolitan Redevelopment Authority prior to the commencement of works;**
- 1.20 any maintenance access being fully designed and constructed to satisfy the City's fleet requirement (such as turning radius, vehicle load and width) regardless whether it is a road, footpath or ramp, with final details being prepared in consultation with the City and confirmation being provided on the final working drawings submitted to, and approved by the Metropolitan Redevelopment Authority prior to the commencement of works;**

(Cont'd)

- 1.21 a Stormwater Management Plan being prepared in consultation with the City and being submitted and approved by the Metropolitan Redevelopment Authority prior to the commencement of works;**
- 1.22 a final staging plan detailing the coordination of the delivery of the public realm being submitted and approved by the Metropolitan Redevelopment Authority, in consultation with the City, prior to the commencement of works;**
- 1.23 a construction management plan being submitted to the Metropolitan Redevelopment Authority and City for approval indicating how it is proposed to manage:**
- a) delivery of materials and equipment to the site;**
 - b) storage of materials and equipment on the site;**
 - c) parking arrangements for contractors and subcontractors;**
 - d) maintaining access to the existing cycle ways, pedestrian pathways and principal shared path (PSP) routes immediately adjacent to the development site, or alternatively, providing alternate routes to the satisfaction of the City; and**
 - e) other matters likely to impact on the surrounding properties;**
- 1.24 a communications plan detailing how public enquiries, complaints and notifications regarding the project construction phase will be managed being prepared and implemented by the applicant. The Communications Plan is to be submitted prior to the commencement of any development works to the satisfaction of the Metropolitan Redevelopment Authority, in consultation with the City;**
- 1.25 details of proposed maintenance access for the proposed boardwalk from the landward and river side being submitted to, and approved by the Metropolitan Redevelopment Authority, in consultation with the City;**
- 1.26 anti-graffiti coatings being applied to all accessible surfaces (where appropriate) with the product and supplier details being to the City's satisfaction prior to application;**

(Cont'd)

- 1.27 *the infrastructure for a CCTV network being incorporated into the development that can also be integrated into the City's existing CCTV network to the City's specifications and satisfaction, with details being provided to the City prior to commencement of works in relation to the infrastructure and servicing for the public realm;*
- 1.28 *a management plan for the alternative bio retention system being submitted for approval by the Metropolitan Redevelopment Authority, in consultation with the City, prior to its installation, including an extended monitoring program to be undertaken by the developer to ensure the long term effectiveness of the system prior to the City taking responsibility for the bio retention infrastructure;*
- 1.29 *a Lighting Strategy for the development being submitted to and approved by the Metropolitan Redevelopment Authority, in consultation with the City, prior to the commencement of works;*
- 1.30 *a comprehensive "as constructed" documentation package including engineering certification relating to structural loading capacity of the development being provided upon completion of works, to the satisfaction of the Metropolitan Redevelopment Authority, in consultation with the City;*
- 1.31 *a Noise and Vibration Management Plan being submitted at the working drawing stage, to the satisfaction of the Metropolitan Redevelopment Authority, in consultation with the City;*
- 1.32 *a comprehensive Fire Emergency Strategy and Management Plan for the development being submitted at the final working drawings stage, to the satisfaction of the Metropolitan Redevelopment Authority, in consultation with the City and Department of Fire and Emergency Services;*
- 1.33 *a dilapidation survey of the footpaths, kerbs, carriageways, buildings and open space areas adjacent to the site being carried out and a copy provided to the satisfaction of the Metropolitan Redevelopment Authority, in consultation with the City prior to the commencement of any works. Any damage caused to these elements shall be made good at the developer's expense upon practical completion of the development;*

(Cont'd)

- 1.34 a simplified and consolidated paving materials palette, with non-standard/alternative materials being limited to specific public interest zones, being prepared in consultation with the City and being submitted to and approved by the Metropolitan Redevelopment Authority prior to the commencement of works;**

Landscaping

- 1.35 the trees proposed within the central median of the Hay Street extension being deleted from the plans in order to maintain the key vista from the city to the river as provided for within the Waterbank Design Guidelines;**
- 1.36 final details of the 'nature play' facility being submitted to and approved by the Metropolitan Redevelopment Authority, in consultation with the City prior to installation;**
- 1.37 final details of the proposed irrigation source and ongoing access to ground water supply/s for the establishment and maintenance of all planted and turfed areas being submitted to and approved by the Metropolitan Redevelopment Authority, in consultation with the City and Department of Water, prior to the commencement of works;**
- 1.38 the use of reticulated water for irrigating or supplementing water supply for landscaping elements not being permitted within the proposed alternative stormwater management system with details of the final design and year round operation of the system being submitted to and approved by the Metropolitan Redevelopment Authority, in consultation with the City and Department of Water, prior to the commencement of works;**
- 1.39 all landscaped areas located adjacent to future development lots being designed and maintained to ensure suitable levels of visual permeability and interaction between future buildings and the streetscape;**

(Cont'd)

Place Activation

- 1.40 a final Place Activation Strategy and a fully costed and detailed place activation implementation plan being submitted to the Metropolitan Redevelopment Authority for approval in consultation with the City, including activity levels and subsidies, and transition planning leading up to and post-handover to the City including strategies to achieve self-sustainability;**
- 1.41 final details of the proposed public art concepts for the various locations within the development being negotiated with the City with a costed detailed Public Art Implementation Plan being submitted including costs, asset management and a maintenance plan across all lifecycle phases with provision for the City to:**
- a) provide comment on the design vision, theming and brief;**
 - b) be represented on the appropriate selection panel;**

Asset Management

- 1.42 a risk and safety assessment and including risk mitigation for the landscaping and public realm across all lifecycle phases being undertaken including:**
- a) service, maintenance and repair activities, access, movement and loading;**
 - b) impact of overshadowing from current and future development within and surrounding Waterbank;**
 - c) soil, tree/plant selection and mix, and irrigation regime suitability in the various micro local environments;**
 - d) impact on the long term health and amenity of retained mature trees including the root zone and canopy, as a result of maintenance on the adjacent public realm, the property boundaries and the building construction;**
 - e) control of invasive roots, root protection from construction activities and underground repairs;**
 - f) green waste generation and disposal volumes;**

(Cont'd)

with submission of evidence of the recommendations of the above assessment being addressed in the final design and construction, and/or maintenance and management plans, to the satisfaction of the City;

- 1.43 submitting as constructed drawings and costs, whole of life costs and design life costs as required in terms of the City of Perth Asset Handover Policy for all assets which will become assets of the City;*
 - 1.44 preparation of a management plan for the City's approval to address the pre and post-handover protection and making good of the completed public realm (including roads and footpaths, above and below ground infrastructure and hard and soft landscaping) including risk assessment and mitigation to maintain the integrity of the public realm finishes during construction on the adjoining development sites within Waterbank; and*
- 2. the Metropolitan Redevelopment Authority be advised that Council acknowledges that any additional detailed design matters will be subject to separate investigation and resolution in accordance with the provisions of the Memorandum of Understanding between the City and Metropolitan Redevelopment Authority (5 August 2014) and the Riverside Project Agreement for Public Asset Design, Approval, Development & Handover between the City and Metropolitan Redevelopment Authority (30 July 2015).*

The motion was put and carried

The votes were recorded as follows:

For: Crs McEvoy, Adamos and Yong

Against: Nil

PL12/16 BARRACK STREET – INTEGRATING PRIVATE REALM INVESTMENT WITH STREETScape WORKS – ANNUAL UPDATE

BACKGROUND:

FILE REFERENCE: P1027696 & P1027697
 REPORTING UNIT: Economic Development
 RESPONSIBLE DIRECTORATE: Economic Development and Activation
 DATE: 18 January 2016
 MAP / SCHEDULE: Schedule 7 – Improvement Model
 Confidential Schedule 8 – Implementation Staging Strategy (Distributed to Elected Members under a separate cover)
 Confidential Schedule 9 – Improvement Snapshot – Annual Update (Distributed to Elected Members under a separate cover)

At its meeting held on **9 December 2014**, Council approved a trial ‘Improvement Model’, targeting grants programs and business incentives specifically related to the \$5 million Barrack Street Project, which was completed in November 2015. This including close collaboration with the private sector, to leverage city enhancements as acknowledged in the City’s Corporate Business Plan. A particular target was the identified 144 dilapidation issues identified in the building audit under a broader Improvement Model for Economic Development:

PLACE RESEARCH	COMPETITIVE ADVANTAGE	IMPROVEMENT METHODOLOGY
<ul style="list-style-type: none"> • Economic • Environmental • Social • Cultural • Physical Environment 	Attributes or combination of attributes may allow a place to outperform its competitors either by cost or a point of differentiation	Having an appropriate governance model for community engagement and capital investment relevant to the place

Table 1: Improvement Model for Economic Development: Three Pillars

At its meeting held on **9 December 2014**, Council resolved the following:

- “1. approves a project to target grant opportunities and incentives detailed in Confidential Schedule 22 [of that report], concurrent with the City’s capital works in Barrack Street, for the purpose of consultation with stakeholders to deliver physical building and tenancies improvements through formal negotiation, business grants, incentives and compliance activities; and
2. supports the priority Issues and Actions outlined in the ‘Improvement Implementation Staging Strategy’ as detailed in Confidential Schedule 20 [of that report], as an appropriate program to progress the identified issues in the Barrack Street study area.”

This approach supports appropriate forward planning of major projects, addresses risk management of committed public funds and maximises the impact of that investment.

The timeline for the trial was three years from December 2014, to accommodate negotiation on the dilapidation issues and monitoring the impact of the City's civil works across the following areas:

- Gross leasable area / value;
- Vacant floor space;
- Gross Rental Value;
- Total number of vacant tenancies;
- Day / Night time economy – opening hours;
- Land use mix (changes);
- Ground Floor Activation Assessment;
- Crime / Antisocial Behaviour data;
- Maintenance of identified cultural business diversity;
- Survey of landowners and tenants; and
- Pedestrian count(s).

These metrics are to be examined at the end of the program.

This report examines the impact of the first year of the Improvement Model on the Street's dilapidation audit. The updated Improvement Model is detailed in Schedule 7³.

LEGISLATION / STRATEGIC PLAN / POLICY:

Legislation	Section 2.7(2)(b) of the <i>Local Government Act 1995</i>
Integrated Planning and Reporting Framework Implications	Corporate Business Plan Council Four Year Priorities: Community Outcomes Perth as a Capital City The City is recognised internationally as a city on the move and for its liveability, talented people, centres of excellence and business opportunities. Living in Perth The City is a place where a diverse range of people choose to live for a unique sustainable urban lifestyle and access to government and private services.

³ Amended typographical error from agenda by changing "Schedule 8" to 'Schedule 7'.

Perth at Night

A City that has a vibrant night time economy that attracts new innovative businesses and events and where people and families feel safe.

Capable and Responsive Organisation

A capable, flexible and sustainable organisation with a strong and effective governance system to provide leadership as a capital city and provide efficient and effective community centred services.

Policy

- Policy No and Name:
- 1.2 – Community Consultation
 - 1.3 – Community Participation
 - 2.3 – Graffiti Treatment
 - 6.1 – Heritage Grants
 - 6.18 – Small Business Grants
 - 6.19 – Business Grants – Matched Funding
 - 9.5 – Sponsorship of City Activities

DETAILS:

Dilapidation Summary

As shown in Table 1 below, 74 of the 144 dilapidation issues noted in the 2014 audit have now been addressed by a combination of implemented works, planning approvals to undertake works (to be implemented), and City of Perth Heritage or Business Grants (in various stages of implementation).

IMPROVEMENT PROGRAM – ACTIONABLE DILAPIDATION ISSUES

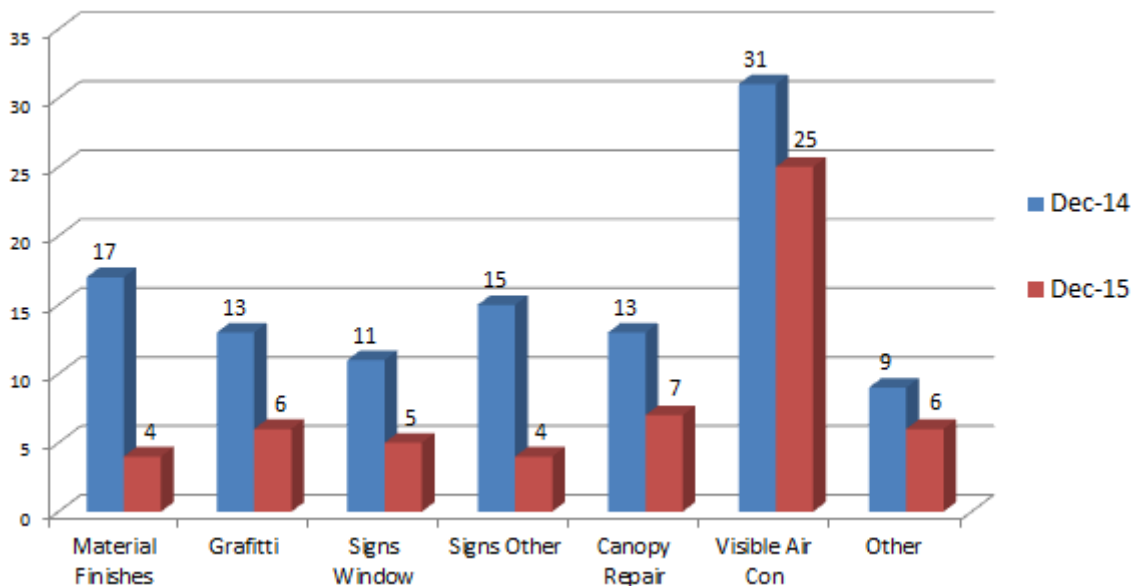

Table 1: Actionable Dilapidation Issues – Annual Update

With limited exception, Stage 1 of the Implementation Staging Strategy, endorsed by Council at its meeting held on **9 December 2014** (refer Confidential Schedule 9), has been completed.

Improvement Program Stages 2 / 3 – Negotiation and Compliance

Incentives to improve building facades were a City initiative to collaborate with the private sector to leverage city enhancements as required by the City's Corporate Business Plan.

Stages 2 and 3 of the Improvement Program require direct negotiation and compliance action to address the remaining dilapidations issues. The legislative framework relevant to the array of dilapidation issues places the onus for works on owner(s) of the land. Any City action in this regard will cause some nuisance to the operation of businesses in the locality with disruption to air conditioning services, hoardings, gantries, footpath obstructions to implement the required works. Accordingly, it is recommended that consideration of compliance action be deferred to the commencement of the 2016/17 financial year, to give business some respite from the combined impacts of:

- (i) Public Transit Authority bus relocation to William Street (loss of foot traffic);
- (ii) Metropolitan Redevelopment Authority (MRA) works at Barrack Square and EQ;
- (iii) two way traffic civil works; and
- (iv) forecast consumer sentiment.

Heritage Grants

At its meeting held on **25 July 2015**, Council conditionally approved the awarding of Heritage Grants, totalling \$135,058 (excluding GST) for the following properties:

1. 119-123 Barrack Street, Perth (\$73,808) – For the removal of the steel cladding from the first and second floors and reinstatement of the original street façade. A Heritage Agreement has been signed and development application recently lodged.
2. The six buildings forming the 'Connor Quinlan Estate' located at 618 Hay Street, 612-616 Hay Street and 69-99 Barrack Street, Perth (\$61,250) – These works include repainting the existing street façades and the award is dependence on the owners' relocation of air conditioning units and concealment of services. The works are currently being programmed by the property manager with the timing to consider an overall canopy upgrade.

Council also authorised the Chief Executive Officer to negotiate with the property owner of 86 Barrack Street regarding the heritage grant and the heritage interpretation of the property. These discussions are still ongoing.

The proposed works will provide the catalyst and critical mass for the transformation of the Conservation Area. The total grant award of \$135,058 has been matched by \$342,384 of direct private investment and a potentially a further \$479,250 in canopy

works for the Connor Quinlan Estate (being the entire western side of Barrack Street between the Malls).

Small Business Grants

A total of seven key tenancies were identified for Small Business Grants of up to \$2,000 in the 2014 audit to address dilapidation issues. A total of five grants have been approved totalling \$8,865, with a further three applications subject to current consideration. This has been a very effective way to provide façade improvements via direct negotiation with tenants resolving approximately 15% of this year's dilapidation improvements.

Other Incentives

It is recommended that Council's endorsed incentive of \$500 per air conditioning unit removal / relocation (up to a maximum of \$1,500 per site) be extended to the 2015/16 financial year. It's likely that the 25 noted air conditioning units currently located on building facades or awnings are unauthorised and in most cases, detract significantly from the visual amenity of the Barrack Street Heritage Conservation Area.

The Stage 2 / 3 (negotiation and compliance) measures endorsed under the Implementation Strategy will be significantly more effective with these funds remaining available. The maximum financial implication in this regard is \$11,000 as summarised in Confidential Schedule 9.

It is anticipated that this will save significant costs in comparison to any legal action relating to unauthorised development.

Targeted Sites

Confidential Schedule 9 includes an Improvement Snapshot outlining the progress on the key targeted sites, improvements and initiatives endorsed by Council at its meeting held on 9 June 2014. All outcomes have been either addressed successfully or are subject to ongoing negotiation.

Other Key Sites

131-141 Murray Street, Perth

The former Greater Union site has been vacant for approximately 12 months with the ground floor tenants vacated to accommodate the approved redevelopment as an 18 level hotel and residential tower. This site has a significant impact on the amenity of the locality by virtue of its scale and position on the corner of Barrack and Murray Streets. Planning and Building approvals were granted in September 2015 to accommodate a ground floor sales office. The City has been advised that the project is progressing and transformer (power supply) works are programmed for the second quarter of 2016.

Treasury Tower – 28 St Georges Terrace, Perth

It is understood the major tenant is targeting occupancy of the tower in mid-2016. The tower will accommodate close to 2000 workers which will have a significant impact on foot fall for Barrack Street businesses.

145-151 Barrack Street, Perth

The planning approval for the six storey commercial building on the site incorporating the existing building façade has now expired. Discussions with the owner's representative in December 2015 indicate that a new application will be forthcoming and is intended to be implemented. This situation will be monitored as the site is subject to significant dilapidation and is inhabited by squatters.

Business Survey Results

The Barrack Street Business Survey was open for comment in May 2015, prior to the commencement of the City's two-way works, with 13 responses received. The results are to be analysed at the end of the three year improvement program. The key observation at this initial point was poor business confidence overall. Respondents also noted antisocial behaviour as the major factor limiting business confidence and growth, with 90% of respondents expressing concern, with civil works a concern for 55% (the next closest response).

In respect to antisocial behaviour, the crime statistics for the locality reduced by approximately 50% in 2015 given the civil works significantly reduced foot fall given the noise and construction activity. The City will continue to liaise with the WA Police to monitor the situation in 2016.

FINANCIAL IMPLICATIONS:

A total of \$143,923 was spent by the City in the 2014/15 financial year in regards to the awarding of Heritage and Small Business Grants.

Private investment contributing to the Improvement Program amounted to \$351,249.

A detailed breakdown of expenditure associated with the Improvement Program is detailed in Confidential Schedule 9.

Costs associated with implementation of Stage 2 are estimated to be under \$20,000, with \$11,000 anticipated to be spent on air conditioning unit relocation / removal incentives and the remaining Small Business Grants currently in negotiation for façade improvements.

COMMENTS:

It is acknowledged within the City's Corporate Business Plan that a sophisticated governance model includes close collaboration with the private sector to leverage city enhancement. This approach supports appropriate forward planning of major projects, addresses risk management of committed public funds and maximises the impact of that investment.

The actions of the Improvement Model in Barrack Street have proven to be a welcome addition to City's civil work improving the amenity and functionality of Barrack Street. With over half the identified dilapidation issues actioned via works or development approvals, significant improvements have occurred and will be apparent in the next 12 to 24 months.

The visual impacts of the secured improvements are likely to be fully realised in the coming 12 months with the heritage works and development approvals being implemented. A presentation incorporating the City's 3D model will be provided to Elected Members in the next annual review.

The post implementation assessment of the proposed Barrack Street project will be used to determine if the Improvement Model can be further developed to drive future concurrent public / private improvements. Pending this assessment, the Improvement Model for current public / private improvements will be developed as a Policy for Council's future consideration.

Moved by Cr Yong, seconded by Cr Adamos

That Council:

- 1. notes that the Barrack Street two way civil works were finalised two months ahead of practical completion;***
- 2. notes that over 50% of the dilapidation issues identified in the 2014 audit have been addressed in the first year of the three year Improvement Program by a combination of implemented works, planning approvals to undertake works, and City Heritage or Business Grants;***
- 3. notes that the targeted sites and measures identified in the Improvement Snapshot included in Confidential Schedule 10 have been actioned and / or achieved, with grants totalling \$143,923 generating \$351,249 of private investment across 13 sites;***
- 4. notes that the Implementation Staging Strategy is moving to Stage 2 / 3 with remaining dilapidation works to be addressed by negotiation and compliance; and***
- 5. approves the continuation of the incentive for the removal / relocation of the remaining 25 air conditioning units on facades located within the Barrack Street Conservation Area, at a maximum cost of \$11,000.***

The motion was put and carried

The votes were recorded as follows:

For: Crs McEvoy, Adamos and Yong

Against: Nil

PL13/16 MOTIONS OF WHICH PREVIOUS NOTICE HAS BEEN GIVEN

Nil

PL14/16 GENERAL BUSINESS

Responses to General Business from a Previous Meeting

Nil

New General Business

1. Design Excellence Framework for Architecture

The Planning Committee queried the City of Perth's approach to improving the aesthetics of our city's architecture. Cr Adamos raised the possibility of developing a new design excellence framework to improve and manage this issue during the approvals process. The Acting Chief Executive Officer advised that a new design excellence framework for architecture is being considered within the City of Perth.

Cr McEvoy advised that a recent news article from New South Wales reported an innovative method of improving aesthetics in architectural design. She suggested that the City of Perth consider the potential benefits of developing and implementing a new "Design Excellence Framework" to address these issues.

2. Data Collection for Place Planning

Cr Adamos suggested the City commence collection of data on "what makes a good place" via an app/software with the intention of planning for better places in the future.

Acting Chief Executive Officer advised that the City of Perth is taking a spatial approach to place-making, which can be seen at the Wellington Square redevelopment. The Acting Chief Executive Officer will take this on notice and consult with Officers to provide the Committee with further information and ideas that could improve the visual design architecture problem in the city.

3. Unsightly Washing on Apartment Balconies

Cr McEvoy queried the City of Perth's ability to prevent washing being hung on balconies of apartment buildings. The Acting Chief Executive Officer advised that in the past, letters have been sent to strata companies to encourage them to get tenants to follow the rules of their buildings. He advised that there is not much else

we can do unless there is a danger to the community but he will take this on notice for future discussion and consideration with upcoming policy reviews.

PL15/16 ITEMS FOR CONSIDERATION AT A FUTURE MEETING**Outstanding Items:**

Nil

PL16/16 CLOSE OF MEETING

6.38pm There being no further business the Presiding Member declared the meeting closed.

**SCHEDULES
FOR THE MINUTES OF THE
PLANNING COMMITTEE
MEETING
HELD ON
27 JANUARY 2016**



2015/5504 - 251-253 (LOTS 10, 11 AND 412) ST GEORGES TERRACE, PERTH



2015/5504 - 251-253 (LOTS 10, 11 AND 412) ST GEORGES TERRACE, PERTH



2015/5504 - 251-253 (LOTS 10, 11 AND 412) ST GEORGES TERRACE, PERTH



2015/5504 - 251-253 (LOTS 10, 11 AND 412) ST GEORGES TERRACE, PERTH



2015/5504 - 251-253 (LOTS 10, 11 AND 412) ST GEORGES TERRACE, PERTH

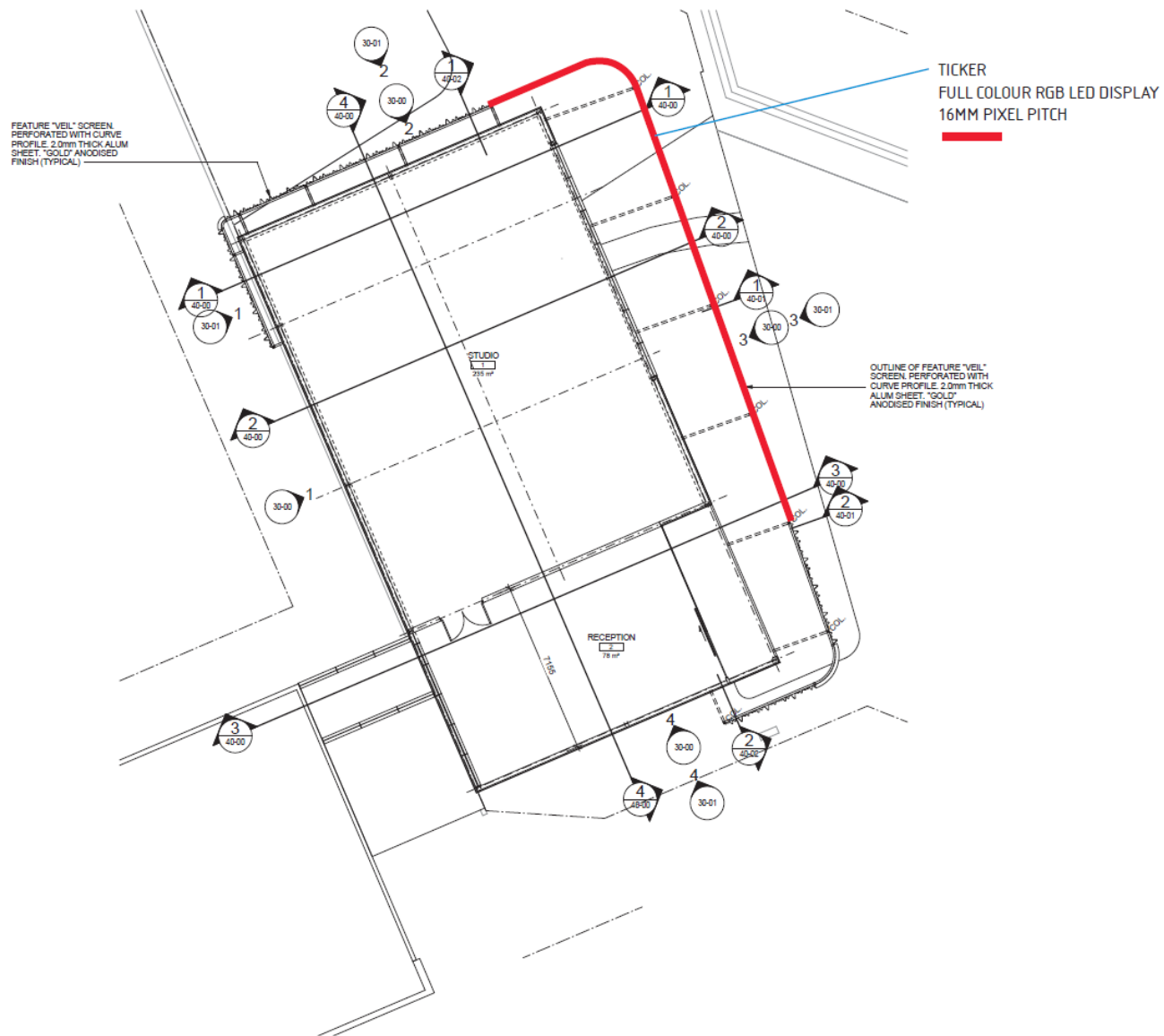

2015/5504 - 251-253 (LOTS 10, 11 AND 412) ST GEORGES TERRACE, PERTH

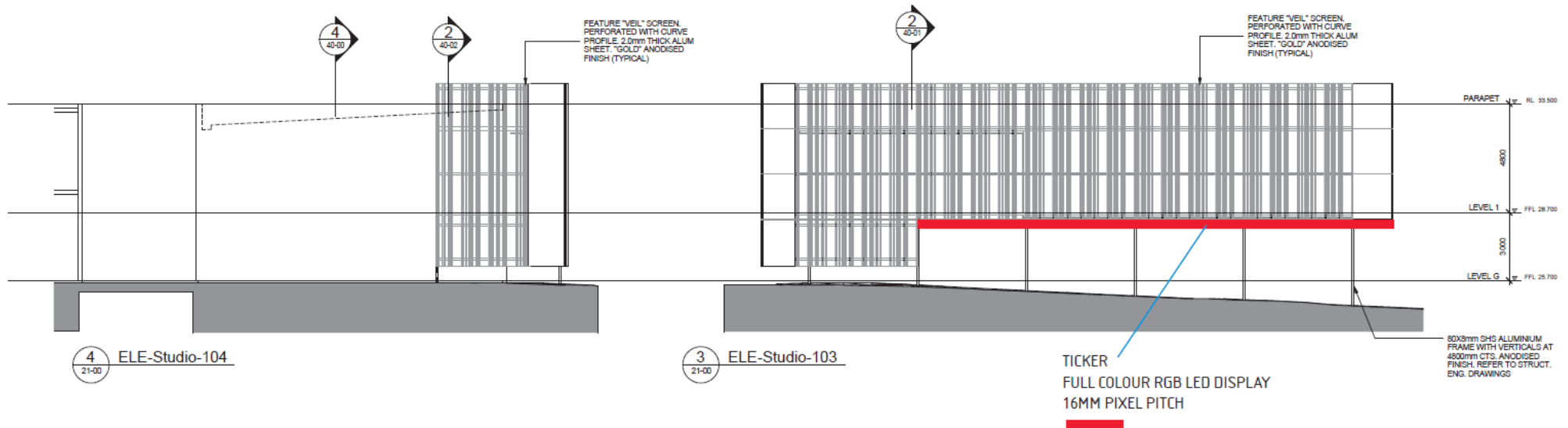
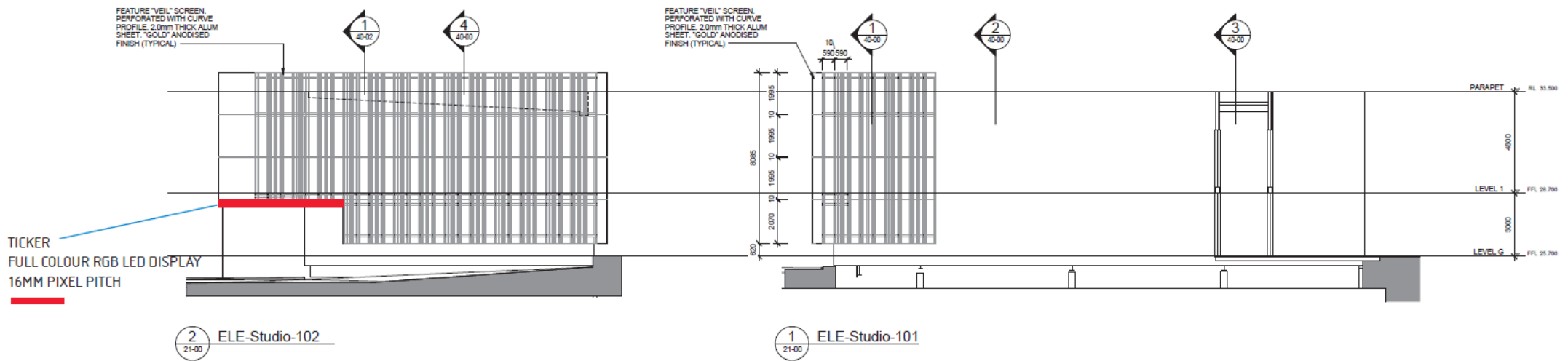

2015/5504 - 251-253 (LOTS 10, 11 AND 412) ST GEORGES TERRACE, PERTH

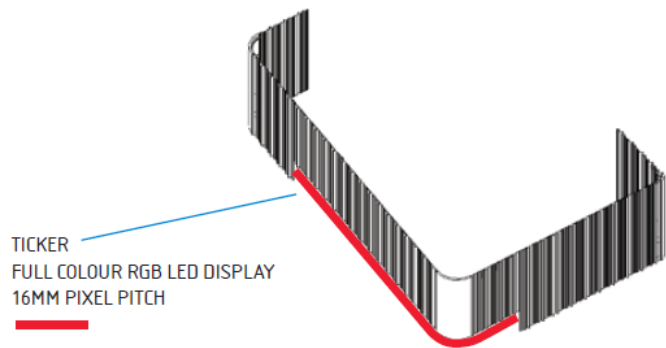

5 3D VEIL VIEW-NE

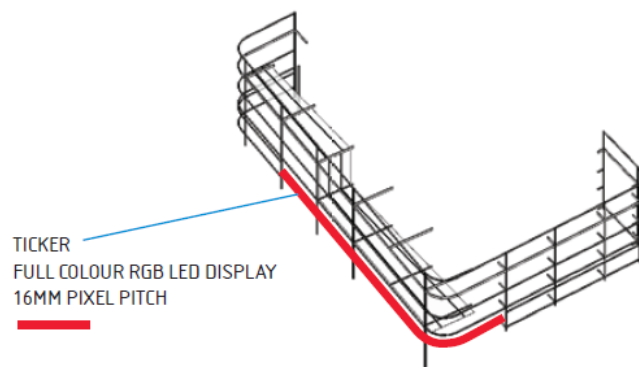

6 3D VEIL STRUCTURE VIEW-NE

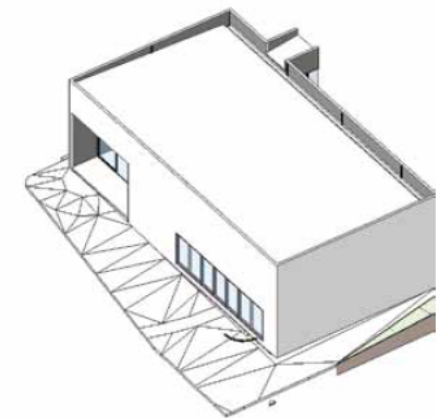

7 3D STUDIO VIEW-NE

2015/5504 - 251-253 (LOTS 10, 11 AND 412) ST GEORGES TERRACE, PERTH

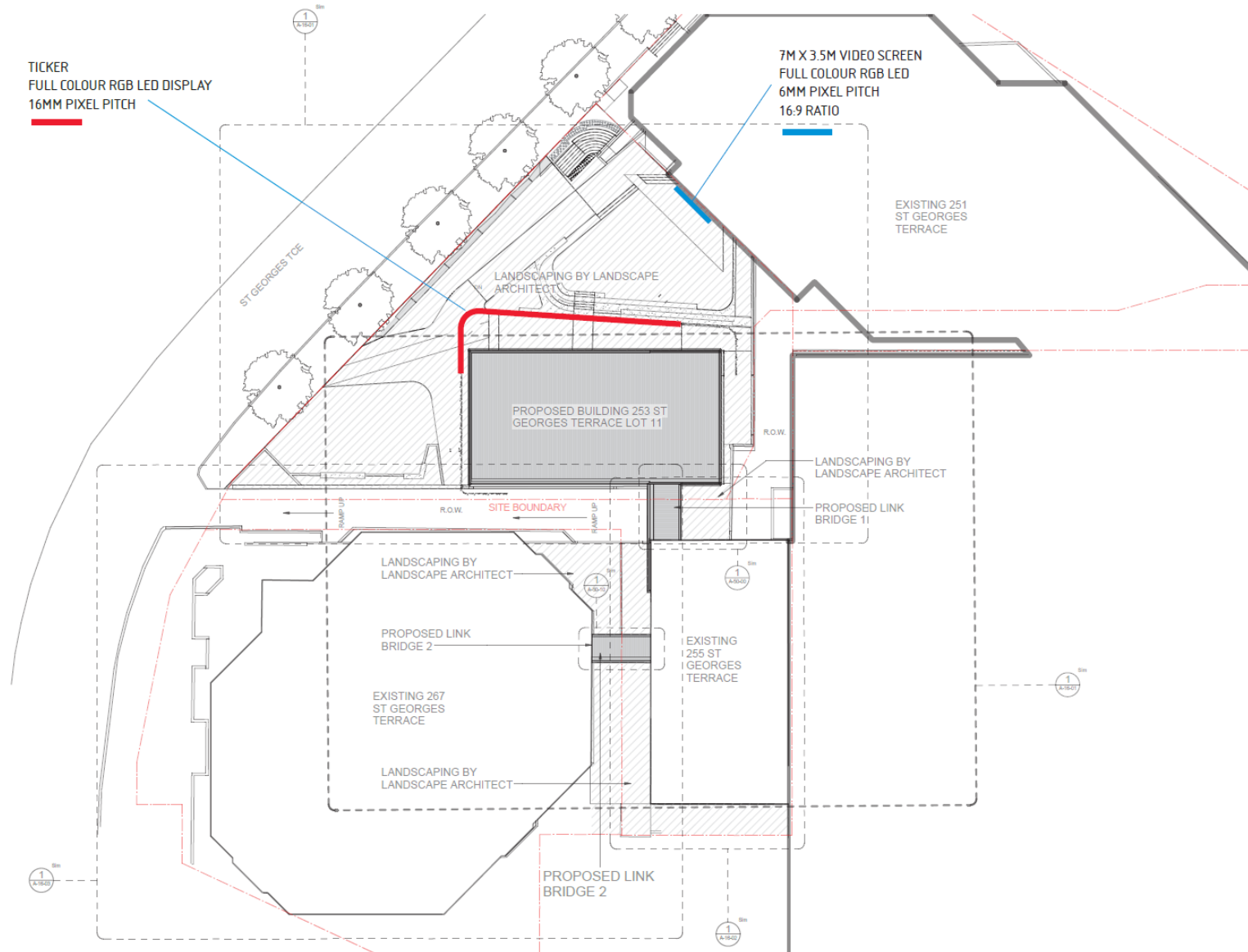

2015/5504 - 251-253 (LOTS 10, 11 AND 412) ST GEORGES TERRACE, PERTH

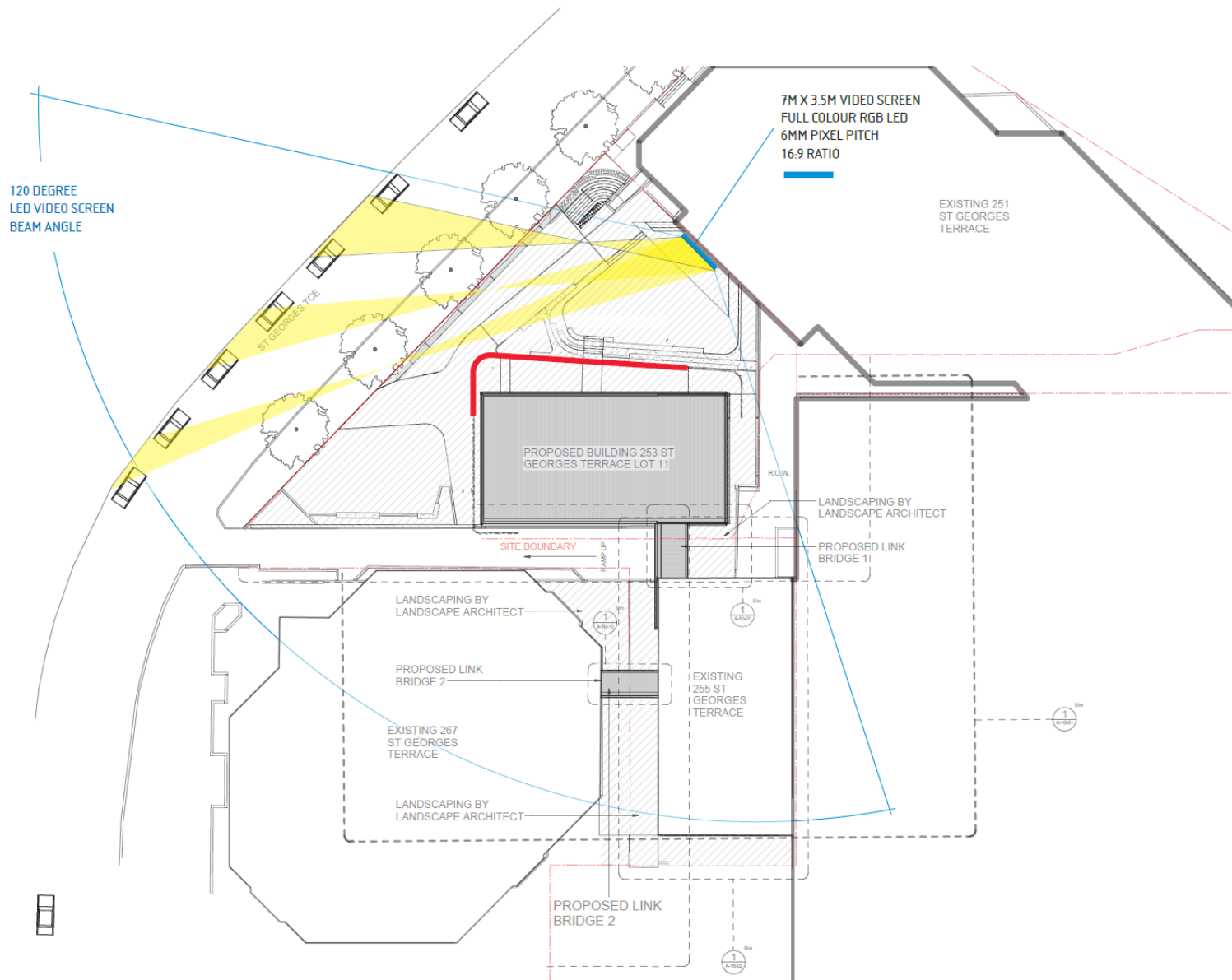

2015/5504 - 251-253 (LOTS 10, 11 AND 412) ST GEORGES TERRACE, PERTH

City Planning Scheme No.2 - Amendment No.33 and P5 Precinct Plan

Overview of Submissions (1 in total)			
Organisation		Comment	City's Response
1.	Government of Western Australia – State Heritage Office	The State Heritage Office notes the proposed Special Control Area is consistent with Condition 20 of the approval issued by the Perth Local Development Assessment Panel and is therefore supportive.	Noted.



CITY of PERTH



Amendment N° 33



CITY of PERTH

PLANNING AND DEVELOPMENT ACT 2005

RESOLUTION DECIDING TO AMEND A TOWN PLANNING SCHEME

CITY OF PERTH

CITY PLANNING SCHEME No. 2 – AMENDMENT No. 33

RESOLVED that the Council, in pursuance of Section 75 of the Planning and Development Act 2005, amend City Planning Scheme No. 2 by:

1. After Clause 57a (1) (t) insert:
 - (u) Melbourne Hotel Special Control Area.
2. Insert the following in Schedule 9 Special Control Areas:

21.0 Melbourne Hotel Special Control Area

21.1 Special Control Area

The following provisions apply to the land marked as Figure 21 – Melbourne Hotel Special Control Area.

21.2 Objectives

- (a) To facilitate the development of the Special Control Area as a whole in a coordinated manner;
- (b) The restoration and maintenance of the Melbourne Hotel building in a good condition with the use of the building being for purposes appropriate to the heritage status and location.

21.3 Heritage

The Melbourne Hotel building shall be restored and thereafter maintained.

21.4 Plot Ratio

For the purpose of determining plot ratio, the total area of the Melbourne Hotel Special Control Area shall be treated as one lot.

21.5 Car Parking

For the purpose of determining the tenant parking allowance under the Perth Parking Policy for any redevelopment as may be defined in the Perth Parking Policy, the Melbourne Hotel Special Control Area shall be treated as one lot.

The tenant parking facilities in one building within the Special Control Area may be leased or used by the tenants of other buildings within the Special Control Area.



CITY of PERTH

3. Amending the City Centre (CC) Precincts Plan (P1 to 8) accordingly.
4. Insert Figure 21 Melbourne Hotel Special Control Area into Schedule 9 – Special Control Areas of the Scheme.

Figure 21 – Melbourne Hotel Special Control Area

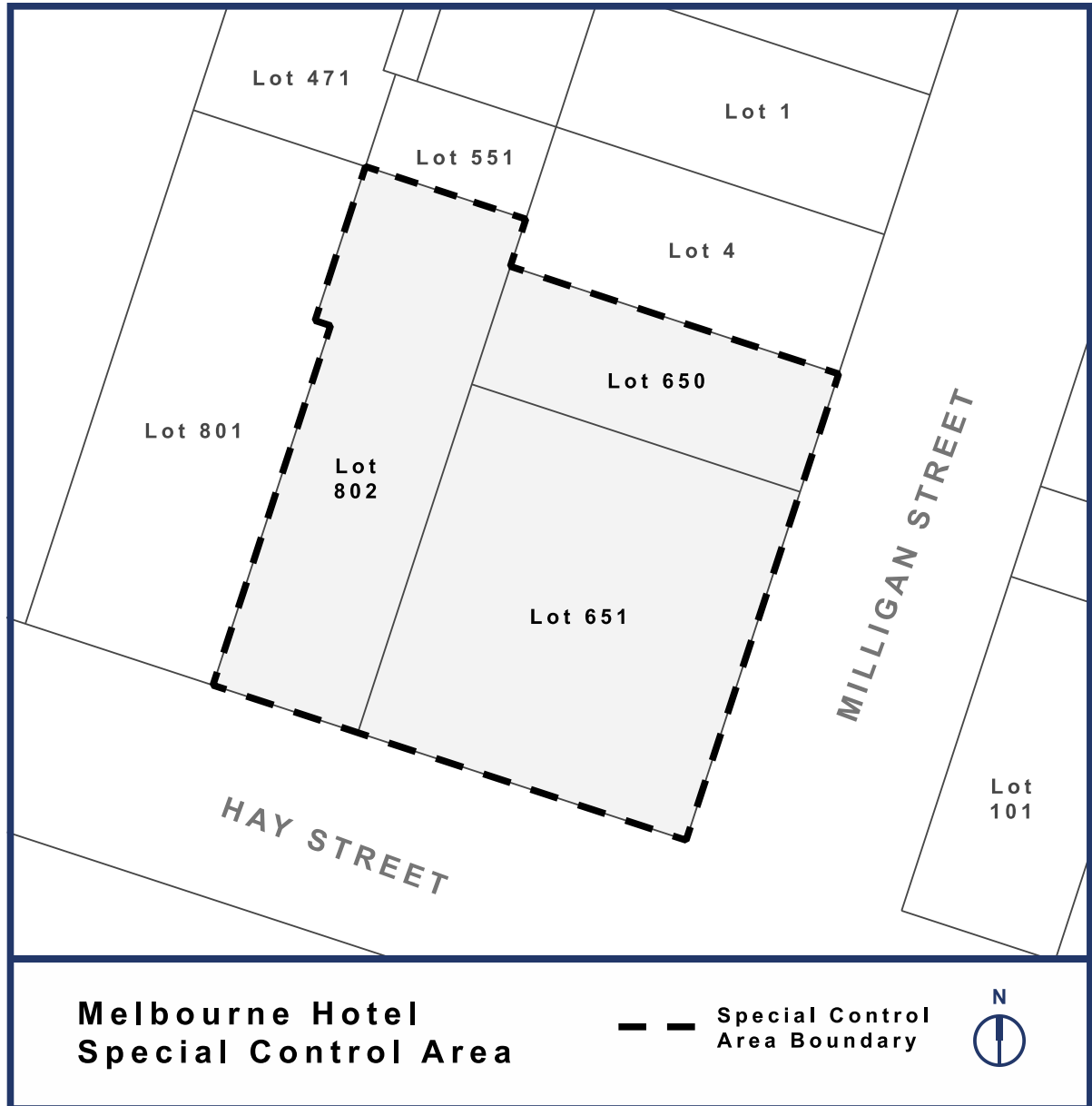

Dated this ____ day of _____ 2015

CHIEF EXECUTIVE OFFICER



CITY of PERTH

PROPOSAL TO AMEND A TOWN PLANNING SCHEME

LOCAL AUTHORITY: CITY OF PERTH

DESCRIPTION OF TOWN
PLANNING SCHEME: CITY PLANNING SCHEME No.2

TYPE OF SCHEME: LOCAL PLANNING SCHEME

AMENDMENT No.: 33

PROPOSAL: Pursuant to section 75 of the Planning and Development Act 2005, the Council initiates the following amendments to City Planning Scheme No.2:

1. After Clause 57A (1) (t) insert:
 - (u) Melbourne Hotel Special Control Area.
2. Insert the following in Schedule 9 Special Control Areas:

21.0 Melbourne Hotel Special Control Area

21.1 Special Control Area

The following provisions apply to the land marked as Figure 21 – Melbourne Hotel Special Control Area.

21.2 Objectives

- (a) To facilitate the development of the Special Control Area as a whole in a coordinated manner;
- (b) The restoration and maintenance of the Melbourne Hotel building in a good condition with the use of the building being for purposes appropriate to the heritage status and location.



CITY of PERTH

21.3 Heritage

The Melbourne Hotel building shall be restored and thereafter maintained.

21.4 Plot Ratio

For the purpose of determining plot ratio, the total area of the Melbourne Hotel Special Control Area shall be treated as one lot.

21.4 Car Parking

For the purpose of determining the tenant parking allowance under the Perth Parking Policy for any redevelopment as may be defined in the Perth Parking Policy, the Melbourne Hotel Special Control Area shall be treated as one lot.

The tenant parking facilities in one building within the Special Control Area may be leased or used by the tenants of other buildings within the Special Control Area.

3. Amending the City Centre (CC) Precincts Plan (P1 to 8) accordingly.
4. Insert Figure 21 – Melbourne Hotel Special Control Area into Schedule 9 – Special Control Areas of the Scheme.



CITY of PERTH

SCHEME AMENDMENT REPORT

1.0 INTRODUCTION

The purpose of this report is to introduce a Special Control Area (SCA) over what is known as the Melbourne Hotel site at 942 and 950 Hay Street and 33 Milligan Street, Perth.

The objective of the Melbourne Hotel Special Control Area is to facilitate the development of the land as a whole in a coordinated manner in order to achieve a high quality outcome for the site.

The Special Control Area will enable the Melbourne Hotel to be subdivided from the proposed office building site while maintaining the integrity of CPS2 and the Approval to Commence Development in terms of plot ratio and tenant car parking.

Special Control Areas provide a mechanism to prescribe development standards for specific sites or areas within the Scheme Area.

2.0 BACKGROUND

The Perth Local Development Assessment Panel at its meeting held on 17 July 2014 approved the construction of a 20 level office development and the conservation of and extensions to the Melbourne Hotel.

The approval was subject to 22 conditions including condition 20, which states that *'the subject lots being amalgamated into one lot on one Certificate of Title prior to occupation of the buildings'*.

The approval also included an advice note which states that *'Further to condition 21 (sic), any future subdivision of the site to enable the hotel and office buildings to be on separate titles will only be able to occur if an amendment to City Planning Scheme No. 2 is approved to establish a Special Control Area over the site whereby plot ratio and tenant car parking is calculated for the site as a whole.'*

3.0 SUBJECT SITE

The subject site includes three lots being 942 (Lot 651) and 950 (Lot 802) Hay Street and 33 (Lot 650) Milligan Street, Perth.

The Melbourne Hotel building exists on 942 Hay Street, while 950 Hay Street and 33 Milligan Street are currently vacant awaiting development. The Melbourne Hotel is listed on the *State Register of Heritage Places* and is also listed on the City's *Register of Places of Cultural Heritage Significance*.



CITY of PERTH



Figure 1 – Aerial Photograph of Site

4.0 PLANNING FRAMEWORK

4.1 Metropolitan Region Scheme

The subject site is zoned Central City Area under the MRS. There are no reservations under the MRS affecting the site.

4.2 City Planning Scheme No. 2

4.2.1 Use Area and precinct

The subject site is located within the Citiplace (P5) Precinct and has a City Centre Use Area. The Statement of Intent for the Citiplace Precinct, relevant to the Melbourne Hotel site, States:

'The Precinct will offer a wide range of general and specialised retail uses as well as a mix of other uses such as residential and visitor accommodation, entertainment, commercial, medical, service industry and minor office. Uses at street and pedestrian level will mainly be shops, restaurants (including cafes), taverns and other uses, that have attractive shop fronts and provide activity, interest and direct customer service. Other uses will be established above or below street level and major pedestrian levels.'

The restoration and maintenance of buildings, groups of buildings and other places which have substantial historical or other significance will be encouraged.'

4.2.2 Preferred and Contemplated Uses

Preferred Uses in the portion of Precinct 5 – Citiplace Precinct include business services, civic, community and cultural, recreation and leisure, entertainment, recreation and leisure, retail and special residential. Contemplated uses include office, mixed commercial and residential.



CITY of PERTH

4.2.3 Plot Ratio

The site is subject to a base plot ratio of 5.0:1, with a maximum 50% bonus plot ratio (1:1) available for eligible Heritage and Public Facilities (20%), Residential (20%) or Special Residential uses (20-40%).

The proposed development was approved with a plot ratio of 5.3:1 (12,223m²), which included a 5.3% (618m²) plot ratio bonus for heritage conservation.

4.2.4 Car Parking

The proposed development was approved with a maximum of 35 tenant car parking bays with the tenant bays being for the exclusive use of occupants of the development (office and hotel buildings) and not being leased or otherwise reserved for use of the tenants or occupants of other buildings or sites.

4.2.5 Heritage

The State Heritage Office noting the identified cultural significance of the Melbourne Hotel building advised that it supported the development of the site subject to the following conditions being imposed:

1. A Heritage Agreement shall be entered into to ensure the ongoing conservation and maintenance of the Melbourne Hotel.
2. A standard archival record shall be prepared according to the State Heritage Office's Guide to Preparing an Archival Record. This record should also include the Hay Street extension proposed for demolition.
3. An Interpretation Plan for the Melbourne Hotel shall be submitted, which illustrates the sequences of development to enhance the understanding of the place to guests and to users.
4. The demolished 1897 fabric in the ground floor breakfast area of the Melbourne Hotel shall be interpreted in the finished floor treatment.
5. A schedule of conservation works to the Melbourne Hotel shall be submitted that outlines the proposed methodology, materials and finishes.

These conditions were included in the Approval to Commence Development.

5.0 THE PROPOSAL

The purpose of this Scheme Amendment is to introduce a Special Control Area over the subject land being 942 (Lot 651) and 950 (Lot 802) Hay Street and 33 (Lot 650) Milligan Street, Perth, to be referred to as the Melbourne Hotel Special Control Area.

The Special Control Area is requested to enable the site to be developed in accordance with the Approval to Commence Development while allowing the site to be subdivided to create a green title lot for the office development and a green title lot for the Melbourne Hotel.

The subject site is unique in that it will contain, upon the ultimate development of the site, a significant heritage building, hotel accommodation and an office building all on the one site. Given the nature of the development and the variety of uses proposed, the future arrangements will require portions of the land/development to be subdivided. Any



CITY of PERTH

subdivision would, however, result in a situation whereby the development would not comply with the plot ratio and tenant parking requirements of CPS2 and would be inconsistent with the conditions imposed on the Approval to Commence Development.

6.0 JUSTIFICATION

Special Control Areas allow for the coordinated development of complex sites by treating the area as one site. A Special Control Area relating to what is known as the Melbourne Hotel would permit the potential subdivision of land whilst maintaining the intent of the planning approval granted and the principles of the CPS2. Furthermore, the City cannot positively recommend a subdivision proposal until a Special Control Area governing the calculation of plot ratio and tenant parking over the whole of the site has been gazetted. This is a reflection of Condition 20 and related advice note in the Approval to Commence Development.

In this particular case, the Special Control Area would enable the different land uses to be subdivided into separate green title lots while maintaining the approved plot ratio and tenant car parking allowance over the site. In turn, this would then allow for the proposed redevelopment of the site to proceed in compliance with CPS2. The Special Control Area will also support the restoration and ongoing maintenance of the Melbourne Hotel, as it would be on its own green title lot and therefore not subject to influences from other parts of the development.

A Special Control Area would ensure that the whole site is developed in the form of a high quality mixed use development while maintaining the heritage significance of the Melbourne Hotel. The Special Control Area will assist the City to meet its objectives in that it will:

- Facilitate the retention, restoration and maintenance of a significant heritage building;
- Provide for additional short stay accommodation;
- Cater for the diversity of demands, interests and lifestyles by facilitating and encouraging the provision of a wide range of choices in housing, business, employment, education, leisure, visitor accommodation and attractions; and
- Co-ordinate and ensure that development is carried out in an efficient and environmentally responsible manner which makes optimum use of the City's growing infrastructure and resources.

7.0 CONCLUSION

The purpose of this amendment to City Planning Scheme 2 is to introduce a Special Control Area over the land situated at 942 and 950 Hay Street and 33 Milligan Street, Perth. Special Control Areas provide a mechanism to prescribe development standards for specific sites or areas within the Scheme Area.

The proposed introduction of the Melbourne Hotel Special Control Area facilitates the redevelopment of the subject site while ensuring the restoration and maintenance of the heritage building.

The proposed Special Control Area is consistent with the relevant statutory framework and would contribute positively to the development of the site and the goals of the City's strategic planning policies.



CITY of PERTH



CITY of PERTH

**PLANNING AND DEVELOPMENT ACT 2005
RESOLUTION DECIDING TO AMEND A TOWN PLANNING SCHEME**

CITY OF PERTH

CITY PLANNING SCHEME NO 2 - AMENDMENT NO 33

RESOLVED that the Council, in pursuance to section 75 of the Planning and Development Act 2005 amend City Planning Scheme No.2 by:

1. After Clause 57A (1) (t) insert:
 - (u) Melbourne Hotel Special Control Area.
2. Insert the following in Schedule 9 Special Control Areas:

21.0 Melbourne Hotel Special Control Area

21.1 Special Control Area

The following provisions apply to the land marked as Figure 21 – The Melbourne Hotel Special Control Area.

21.2 Objectives

- (a) To facilitate the development of the Special Control Area as a whole in a coordinated manner;
- (b) The restoration and maintenance of the Melbourne Hotel building in a good condition with the use of the building being for purposes appropriate to the heritage status and location.

21.3 Heritage

The Melbourne Hotel building shall be restored and thereafter maintained.

21.4 Plot Ratio

For the purpose of determining plot ratio, the total area of the Melbourne Hotel Special Control Area shall be treated as one lot.

21.4 Car Parking

For the purpose of determining the tenant parking allowance under the Perth Parking Policy for any redevelopment as may be defined in the Perth Parking Policy, the Melbourne Hotel Special Control Area shall be treated as one lot.

The tenant parking facilities in one building within the Special Control Area may be leased or used by the tenants of other buildings within the Special Control Area.

3. Amending the City Centre (CC) Precincts Plan (P1 to 8) accordingly.



CITY of PERTH

4. Insert Figure 21 Melbourne Hotel Special Control Area into Schedule 9 – Special Control Areas of the Scheme.

Figure 21 – Melbourne Hotel Special Control Area

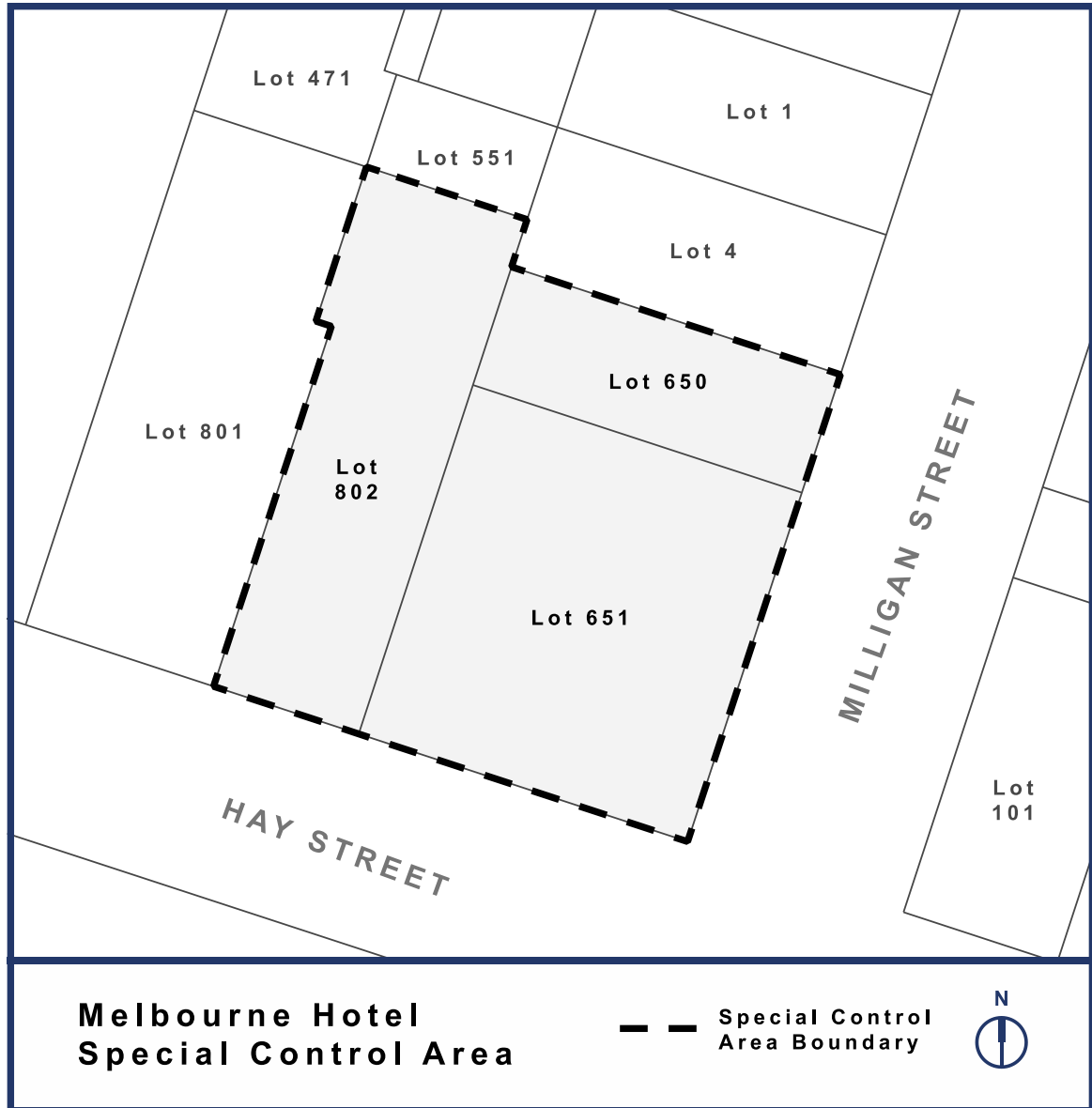



CITY of PERTH

ADOPTION

Adopted by resolution of the City of Perth at the Ordinary Meeting of the Council held
on the ____ day of _____ 2015.

LORD MAYOR

CHIEF EXECUTIVE OFFICER



CITY of PERTH

FINAL ADOPTION

Adopted for final approval by the City of Perth at the Ordinary Meeting of the Council held on the on the ____ day of _____ 2015, and the Common Seal of the City of Perth was hereunto affixed by the authority of a resolution of the Council in the presence of:

LORD MAYOR

CHIEF EXECUTIVE OFFICER

Recommended / Submitted for Final Approval

DELEGATED UNDER S.16 OF PD ACT 2005

DATE

FINAL APPROVAL GRANTED

MINISTER FOR PLANNING

DATE



CITY of PERTH

Schedule 1

Existing City Centre Precincts Plan (P1 to P8)

CITY CENTRE:

Will continue to develop as the focus of business, retail, civic, cultural and entertainment activities in Western Australia

PRECINCTS:

The City Centre contains the following Precincts

- P1 - Northbridge
- P2 - Cultural Centre
- P3 - Stirling
- P4 - Victoria
- P5 - Citiplace
- P6 - St Georges
- P7 - Civic
- P8 - Foreshore

PARLIAMENT HOUSE AND SURROUNDS:

A Clause 32 area which maintains the visual prominence of Parliament House and the aesthetic quality of development in the area.

MINOR TOWN / LOCAL PLANNING SCHEMES (TPS / LPS):

The additional Schemes which apply in the city centre are:

- TPS 11 - Wesley Trust and WA Travel Centre
- TPS 13 - State Government Insurance Office
- TPS 16 - David Jones Site (now Central Park)
- TPS 21 - FAI Site
- TPS 23 - Paragon
- LPS 26 - Normalised Redevelopment Areas

SPECIAL CONTROL AREAS

Special control areas apply in the city centre for these areas:

- 2 - CTA Building
- 5 - 240 St Georges Tce & 899-915 Hay St
- 6 - 141 & 125-137 St Georges Tce & 18 Mounts Bay Road
- 8 - 126-144 Stirling Street
- 11 - 225-239 St Georges Tce (Bishops See)
- 12 - 298-316 Murray Street
- 15 - 92-120 Roe Street
- 17 - St Martins
- 18 - 30 Beaufort Street

PLANNING POLICIES:

Planning and design guidelines apply in the city centre for these areas:

- James, William, Roe and Lake Street
- King Street
- Goderich
- William Street Station Precinct

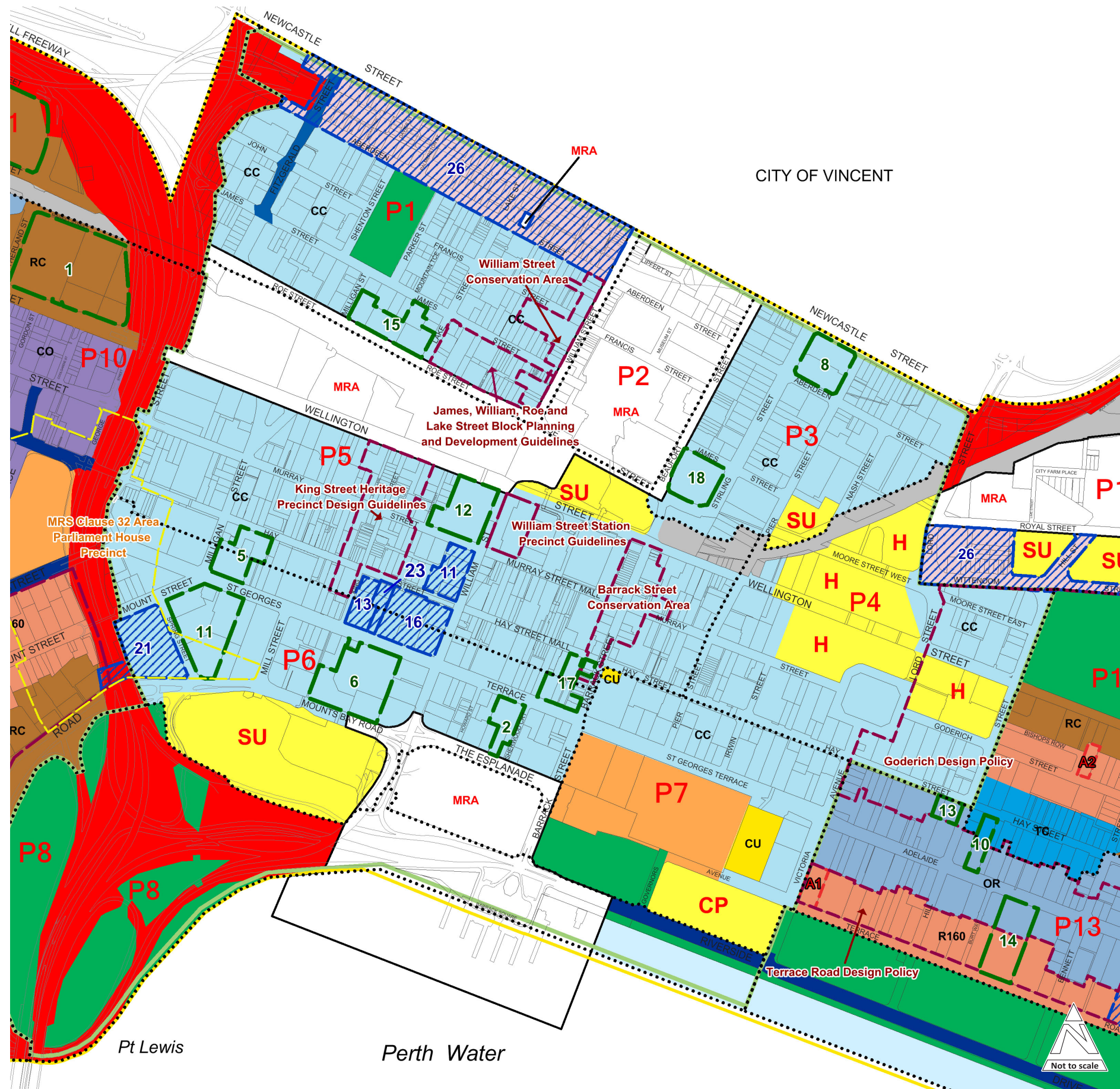

LEGEND

Scheme Area Boundary	
CITY OF PERTH SCHEME RESERVES	
Parks & Recreation	
Public Purposes - Civic Use	
CITY OF PERTH SCHEME USE AREAS	
City Centre	
Town Centre	
Residential	
Office/Residential	
Residential/Commercial	
Commercial	
OTHER	
Additional Uses	
Normalised Redevelopment Area	
Metropolitan Redevelopment Authority Area	
City Centre Boundary	
MRS Clause 32 Area	
Minor Town / Local Planning Schemes and Number	
Special Control Areas and Number	
Other Planning Control Areas	
Precinct Boundary	
Precinct Number	
METROPOLITAN REGION SCHEME RESERVES	
Parks & Recreation	
Railways	
Civic & Cultural	
Waterways	
Public Purposes	
• Hospital	
• Car Park	
• University	
• SECWA	
• Special Uses	
ROADS	
• Primary Regional Roads	
• Other Regional Roads	
NOTE: The Department of Planning should be consulted for full information on the actual land requirements for all Metropolitan Region Scheme Reserves	



CITY of PERTH

Schedule 2

Proposed City Centre Precincts Plan (P1 to P8)

CITY CENTRE:

Will continue to develop as the focus of business, retail, civic, cultural and entertainment activities in Western Australia

PRECINCTS:

The City Centre contains the following Precincts

- P1 - Northbridge
- P2 - Cultural Centre
- P3 - Stirling
- P4 - Victoria
- P5 - Citiplace
- P6 - St Georges
- P7 - Civic
- P8 - Foreshore

PARLIAMENT HOUSE AND SURROUNDS:

A Clause 32 area which maintains the visual prominence of Parliament House and the aesthetic quality of development in the area.

MINOR TOWN / LOCAL PLANNING SCHEMES (TPS / LPS):

The additional Schemes which apply in the city centre are:

- TPS 11 - Wesley Trust and WA Travel Centre
- TPS 13 - State Government Insurance Office
- TPS 16 - David Jones Site (now Central Park)
- TPS 21 - FAI Site
- TPS 23 - Paragon
- LPS 26 - Normalised Redevelopment Areas

SPECIAL CONTROL AREAS

Special control areas apply in the city centre for these areas:

- 2 - CTA Building
- 5 - 240 St Georges Tce & 899-915 Hay St
- 6 - 141 & 125-137 St Georges Tce & 18 Mounts Bay Road
- 8 - 126-144 Stirling Street
- 11 - 225-239 St Georges Tce (Bishops See)
- 12 - 298-316 Murray Street
- 15 - 92-120 Roe Street
- 17 - St Martins
- 18 - 30 Beaufort Street
- 21 - Melbourne Hotel

PLANNING POLICIES:

Planning and design guidelines apply in the city centre for these areas:

- James, William, Roe and Lake Street
- King Street
- Goderich
- William Street Station Precinct



LEGEND

Scheme Area Boundary	
CITY OF PERTH SCHEME RESERVES	
Parks & Recreation	
Public Purposes - Civic Use	
CITY OF PERTH SCHEME USE AREAS	
City Centre	
Town Centre	
Residential	
Office/Residential	
Residential/Commercial	
Commercial	
OTHER	
Additional Uses	
Normalised Redevelopment Area	
Metropolitan Redevelopment Authority Area	
City Centre Boundary	
MRS Clause 32 Area	
Minor Town / Local Planning Schemes and Number	
Special Control Areas and Number	
Other Planning Control Areas	
Precinct Boundary	
Precinct Number	
METROPOLITAN REGION SCHEME RESERVES	
Parks & Recreation	
Railways	
Civic & Cultural	
Waterways	
Public Purposes	
Hospital	
Car Park	
University	
SECWA	
Special Uses	
ROADS	
Primary Regional Roads	
Other Regional Roads	

NOTE: The Department of Planning should be consulted for full information on the actual land requirements for all Metropolitan Region Scheme Reserves

Planning Committee
Confidential Schedule 5
(Minute PL10/16 refers)

Distributed to Elected Members under separate cover

Bound in Consolidated Committee
Confidential Minute Book
Volume 1 2015

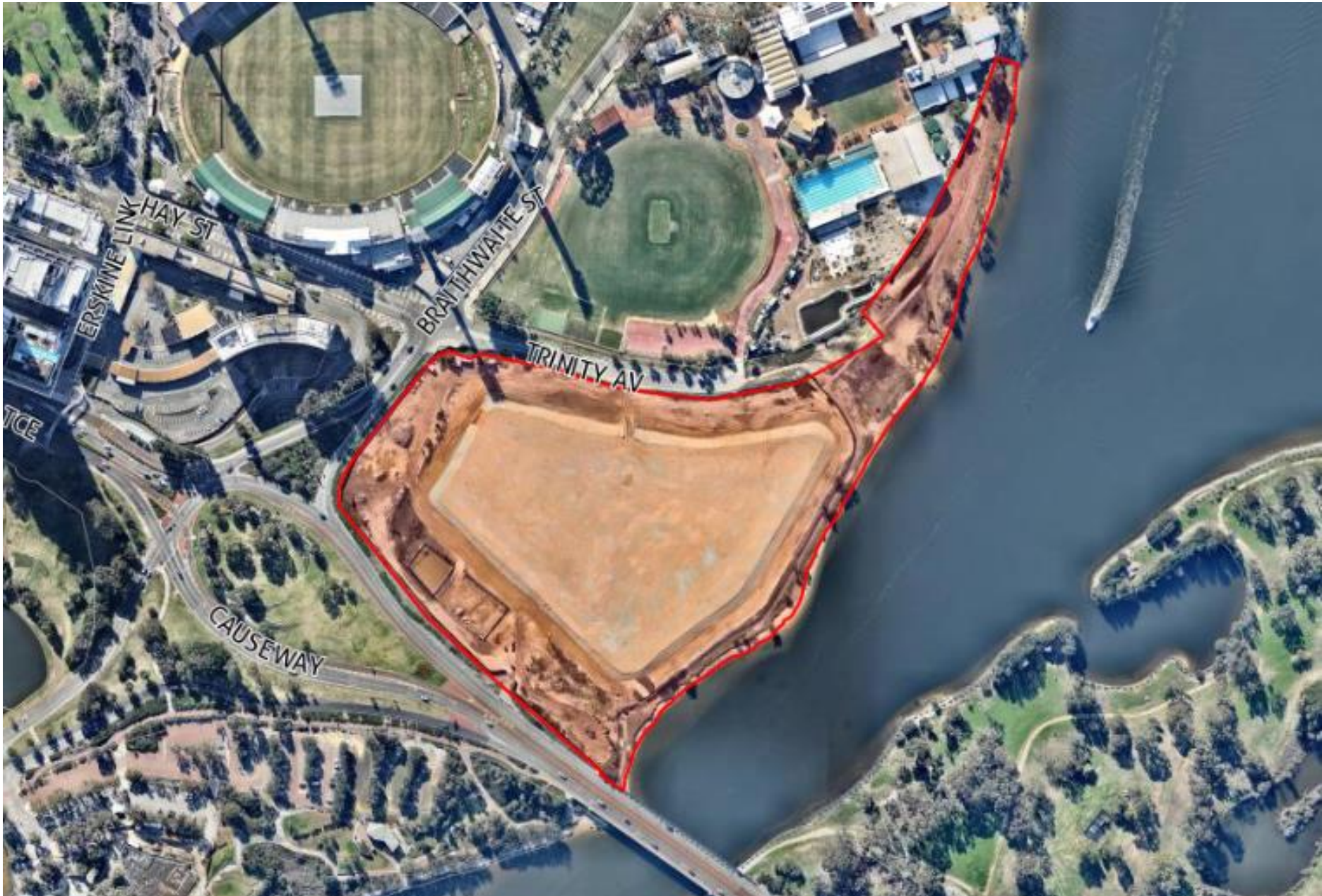

2015/5464 – WATERBANK PUBLIC DOMAIN AND INFRASTRUCTURE WORKS – LOCATION PLAN

SCHEDULE 7

IMPROVEMENT MODEL

STAGE	KEY ACTIVITIES	DEC 14	DEC 15	ACTION / OUTPUT
Research	Review 5 Year Capital Works	X	X	Director to endorse application of model to identified portion of the capital works program
	Review Relevant Grants	X	X	
	Review Relevant Legislation	X	X	
	Status of development approvals	X	X	
	Heritage assessments / context	X	X	
Assessment	Review Strategic Context	X	X	Base data and opportunities identified in an Improvement Snapshot for Council's consideration
	Dilapidation Survey	X	X	
	Land Use Survey	X	X	
	Activation Assessment	X	X	
	Key focus areas identified	X	X	
	Economic Analysis	/	X	
	Commercial culture understood	X	X	
	Establish other baseline data	X	X	
	Pre Consultation Analysis	X	X	
Identify Stakeholders	X	X		
Engagement and Visioning	Communications Plan (Stage 1)		X	Council to endorse options for concurrent private and public realm upgrades
	Engage Stakeholders		X	
	Survey business / land owners		X	
	Review Analysis		X	
	Set Vision		X	
	Set Short / Long Term Objectives		X	
	Identify Strategic Opportunities		X	
	Identify Marketing Opportunities		X	
	Identify Sustainable Funding Options		X	
	Identify Private Investment Options		X	
	Outline Actions		X	
Implementation	Communications Plan (Stage 2)		X	Grants, sponsorship, compliance work, building upgrades, promotion and events completed
	Stakeholder Engagement		/	
	Delivery of identified priorities		/	
	Aquittal / application of funding		/	
	Assistance in negotiation application processes		/	
	Implement branding and marketing opportunities		/	
	Promotion and launch events		X	
Evaluation and Monitoring	Revisit 'Assessment' stage against base indicators		/	Improvements against base line data are reportable within the City's Economic Development Annual Report for the two years following completion of capital works
	Finalise 'Lessons Learnt Register'		/	
	Review methodology / model			
	Recommend improvements to City process and policy		/	
	Review marketing outcomes			
	Survey Businesses			

Key	
X	Completed
/	On-going
	Outstanding

Planning Committee
Confidential Schedules 8 and 9
(Minute PL12/16 refers)

Distributed to Elected Members under separate cover

Bound in Consolidated Committee
Confidential Minute Book
Volume 1 2015